



Rockford Sanitary Systems, Inc.

ROCKFORD, IL 61125-0963

(815) 229-5077 - (800) 747-5077 - FAX (815) 229-5108

WEB SITE-www.rkfdseparators.com E MAIL-rssem@rkfdseparators.com

MODEL NO. RLS-20

LINT SEPARATOR

DRAWN BY

QUOTE #

JOB NAME

W.R.W.

INLET

13.37

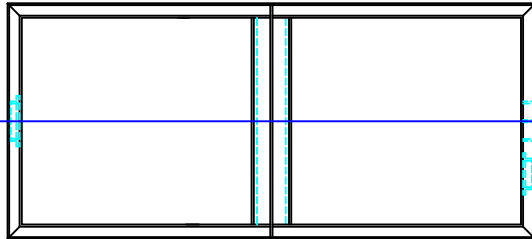

OUTLET

VENT

OPTIONAL FEATURES (ADDITIONAL COST)

- ANCHOR FLANGE
- CLAMP RING
- RECESSED LIFT HANDLES IN COVERS
- EPOXY COATING
- ANODES
- REINFORCED COVER
- STAINLESS STEEL CONSTRUCTION
- INTEGRAL EXTENSION _____ INCHES
- ALUMINUM COVER
- ALTERNATE INLET & OUTLET SIZE _____ INCHES
- ALTERNATE VENT CONNECTION SIZE _____ INCHES
- DOUBLE WALL CONSTRUCTION
- LEAK DETECTION

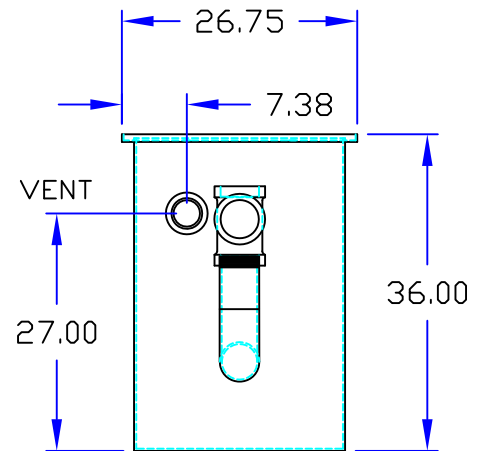
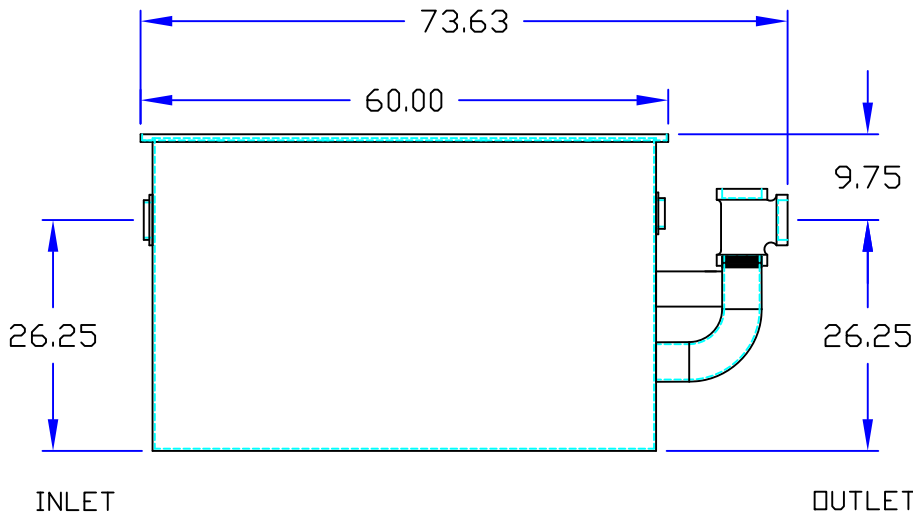

Specifications

Rockford Model RLS-20 all welded 1/4" steel separator, 150 gallon static holding capacity, 4.00" tapped inlet/outlet with 3.00" tapped internal vent connection, visible double-wall outside trap seal, easily removeable filter for cleaning, removable 3/8" nonskid diamond treadplate cover for flush with floor installation suitable for pedestrian traffic secured with stainless flat head screws, heavy duty leak-proof gasket, PPEX Shop Coat coating inside and bituminous coating outside.

Optional features (Additional cost) listed above

Approved By

Company

Date