



Rockford Sanitary Systems, Inc.

ROCKFORD, IL 61125-0963

(815) 229-5077 - (800) 747-5077 - FAX (815) 229-5108

WEB SITE-www.rkfdseparators.com E MAIL-rssem@rkfdseparators.com

MODEL NO. GOST-5630-100

OIL/SAND SEPARATOR

DRAWN BY QUOTE #  
W.R.W.

JOB NAME

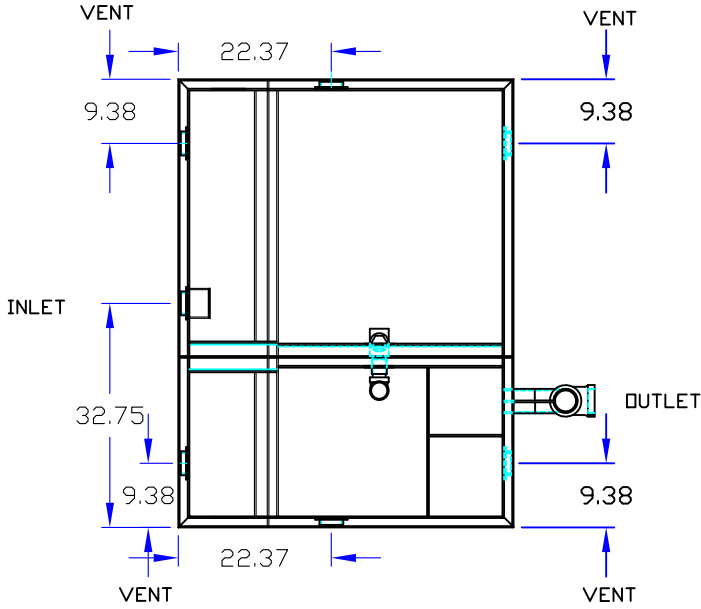

OPTIONAL FEATURES (ADDITIONAL COST)

- ANCHOR FLANGE
- FILTER MEDIUM
- RECESSED LIFT HANDLES IN COVERS
- EPOXY COATING
- ANODES
- REINFORCED COVERS \_\_\_\_\_ LOAD
- STAINLESS STEEL CONSTRUCTION
- SEDIMENT BASKET
- INTEGRAL EXTENSION \_\_\_\_\_ INCHES
- INLET & OUTLET SIZE \_\_\_\_\_ INCHES
- DOUBLE WALL CONSTRUCTION
- LEAK DETECTION
- HIGH LEVEL SENSOR & ALARM
- COALESCING PACK
- PUMP OUT CONNECTION
- HOLD DOWN PADS
- STORAGE COMPARTMENT LADDER
- ALUMINUM COVER
- NO HUB CONNECTION
- HUB CONNECTION

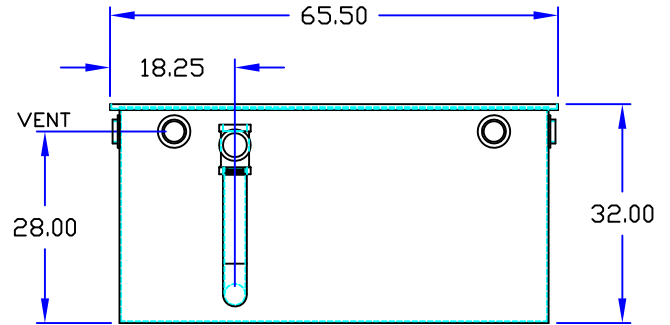
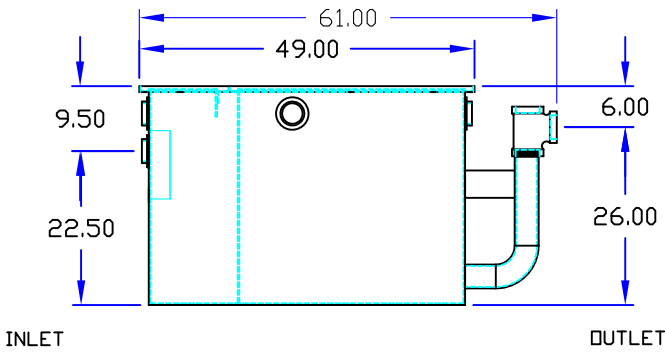

## Specifications

Rockford model GOST-5630-100 oil/water separator all welded A36 .25" steel, 50 gpm intermittent flow, 75 gallon static capacity with 100 gallon waste oil storage and an additional 80 gallon sediment chamber, 3" threaded in/out and 3" threaded vent connections, visible double wall outside trap seal, removable filter screen, non removable separator baffles, .37" nonskid treadplate covers for flush with floor installation suitable for pedestrian traffic secured with stainless steel bolts, heavy duty gasket, opex shop coat inside and bituminous coating outside.

Optional features (Additional cost) listed above



Approved By

Company

Date