



Rockford Sanitary Systems, Inc.

ROCKFORD, IL 61125-0963

(815) 229-5077 - (800) 747-5077 - FAX (815) 229-5108

WEB SITE-www.rkfdseparators.com E MAIL-rssem@rkfdseparators.com

MODEL NO. GOST-5642-200

OIL/SAND SEPARATOR

DRAWN BY QUOTE #
W.R.W.

JOB NAME

OPTIONAL FEATURES (ADDITIONAL COST)

- ANCHOR FLANGE
- FILTER MEDIUM
- RECESSED LIFT HANDLES IN COVERS
- EPOXY COATING
- ANODES
- REINFORCED COVERS _____ LOAD
- STAINLESS STEEL CONSTRUCTION
- SEDIMENT BASKET
- INTEGRAL EXTENSION _____ INCHES
- INLET & OUTLET SIZE _____ INCHES
- DOUBLE WALL CONSTRUCTION
- LEAK DETECTION
- HIGH LEVEL SENSOR & ALARM
- COALESCING PACK
- PUMP OUT CONNECTION
- HOLD DOWN PADS
- STORAGE COMPARTMENT LADDER

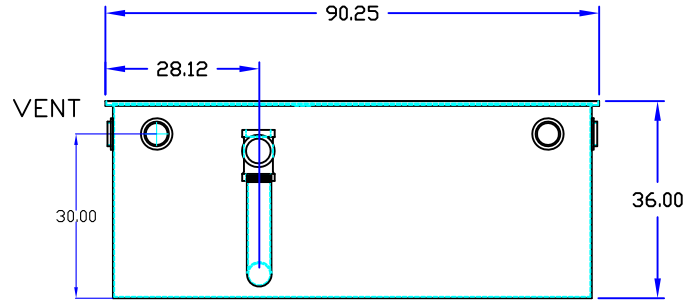
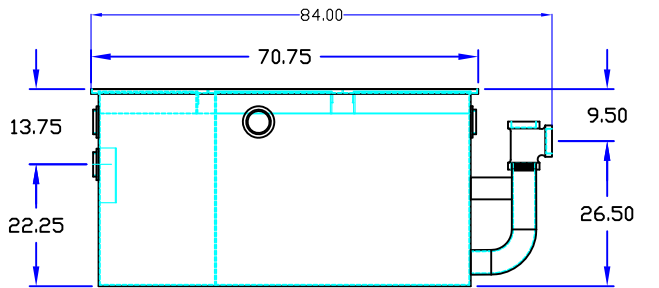
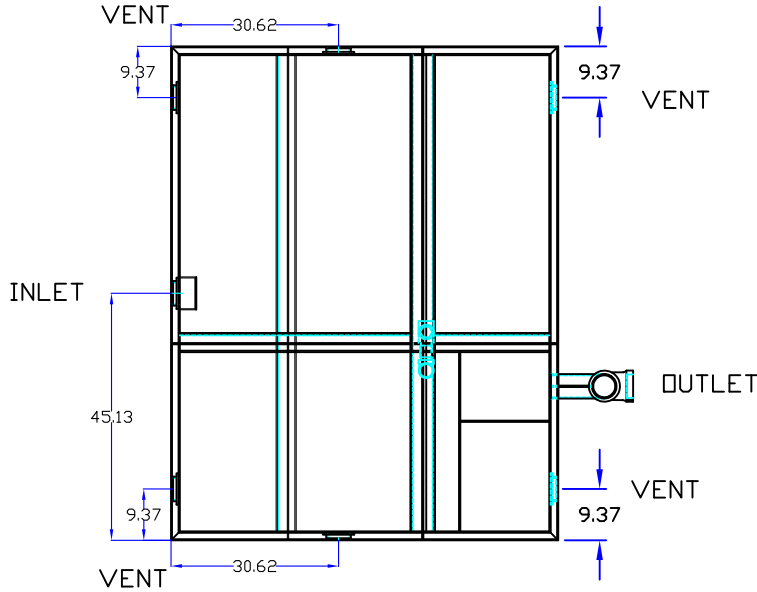

INLET OUTLET

Specifications

Rockford model GOST-5642-200 oil/water separator all welded A36 .25" steel, 100 gpm intermittent flow, 172 gallon static capacity with 200 gallon waste oil storage and an additional 200 gallon sediment chamber, 4" threaded in/out and 4" threaded vent connections, visible double wall outside trap seal, removable filter screen, non removable separator baffles, .37" nonskid treadplate covers for flush with floor installation suitable for pedestrian traffic secured with stainless steel bolts, heavy duty gasket, opex shop coating inside and bituminous coating outside.

Optional features (Additional cost) listed above



Approved By

Company

Date