



Rockford Sanitary Systems, Inc.

ROCKFORD, IL 61125-0963

(815) 229-5077 - (800) 747-5077 - FAX (815) 229-5108

WEB SITE-www.rkfdseparators.com E MAIL-rssem@rkfdseparators.com

MODEL NO.

GOST-5648-300

OIL/SAND SEPARATOR

DRAWN BY

QUOTE #

JOB NAME

W.R.W.

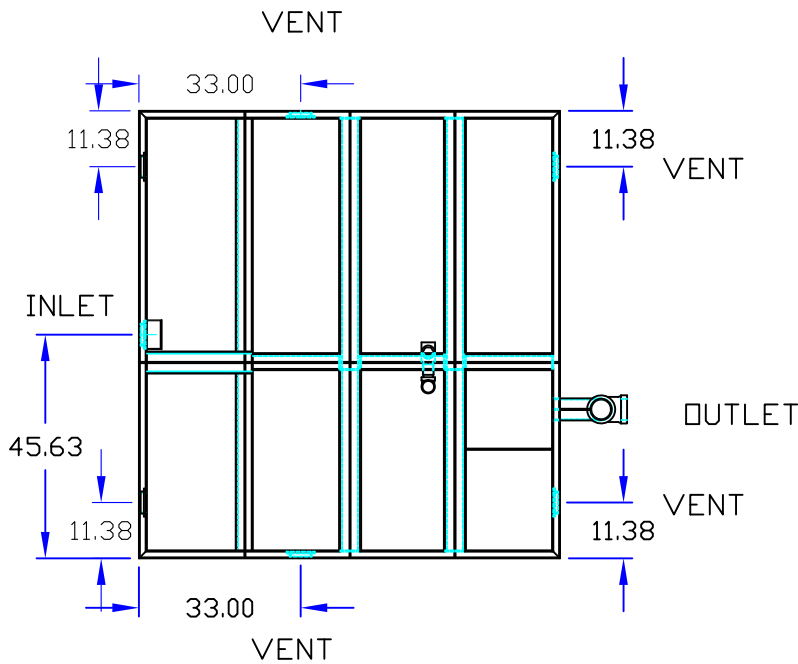

OPTIONAL FEATURES (ADDITIONAL COST)

- ANCHOR FLANGE
- FILTER MEDIUM
- RECESSED LIFT HANDLES IN COVERS
- EPOXY COATING
- ANODES
- REINFORCED COVERS _____ LOAD
- STAINLESS STEEL CONSTRUCTION
- SEDIMENT BASKET
- INTEGRAL EXTENSION _____ INCHES
- INLET & OUTLET SIZE _____ INCHES
- DOUBLE WALL CONSTRUCTION
- LEAK DETECTION
- HIGH LEVEL SENSOR & ALARM
- COALESCING PACK

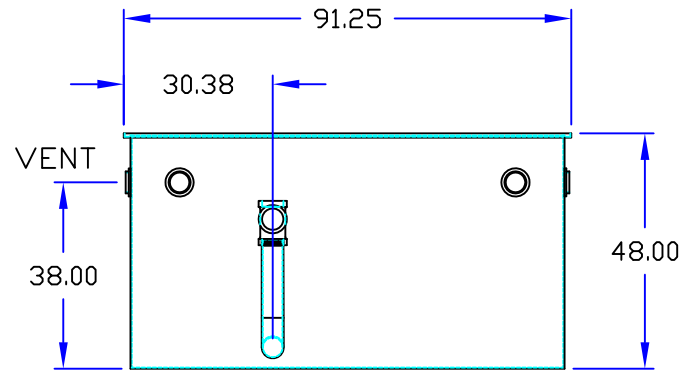
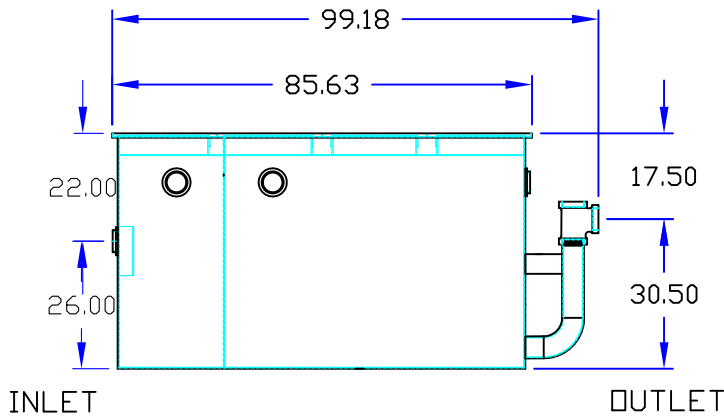

Specifications

Rockford model GOST-5648-300 oil/water separator all welded A36 .25" steel, 200 gpm intermittent flow, 285 gallon static capacity with 300 gallon waste oil storage and an additional 230 gallon sediment chamber, 4" threaded in/out and 4" threaded vent connections, visible double wall outside trap seal, removable filter screen, non removable separator baffles, .37" nonskid treadplate covers for flush with floor installation suitable for pedestrian traffic secured with stainless steel bolts, heavy duty gasket, opex shop coating inside and bituminous coating outside.

Optional features (Additional cost) listed above

Approved By

Company

Date