



Rockford Sanitary Systems, Inc.

ROCKFORD, IL 61125-0963

(815) 229-5077 - (800) 747-5077 - FAX (815) 229-5108

WEB SITE-www.rkfdseparators.com E MAIL-rssem@rkfdseparators.com

MODEL NO.

OSL-5628

OIL/WATER SEPARATOR

DRAWN BY

QUOTE #

JOB NAME

W.R.W.

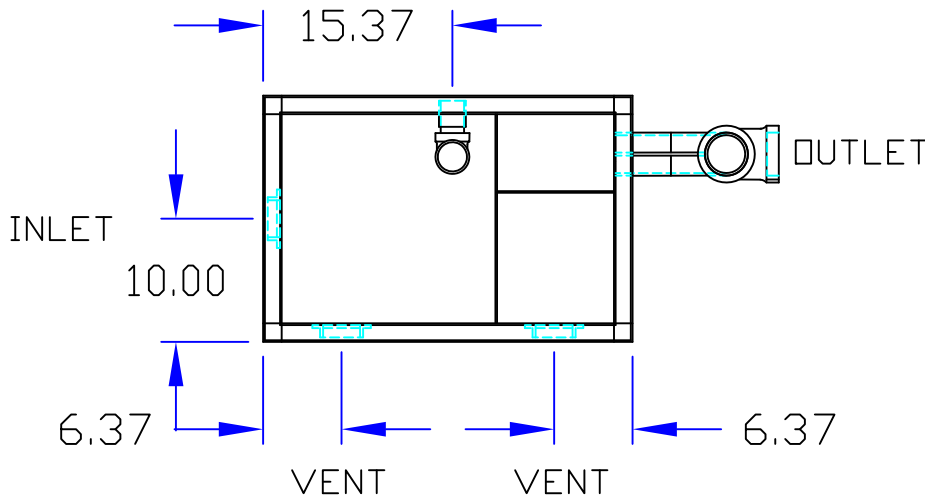

OPTIONAL FEATURES (ADDITIONAL COST)

- ANCHOR FLANGE
- RECESSED LIFT HANDLES ___ PER COVER
- EPOXY COATING
- LIGHT TRAFFIC REINFORCED COVERS
- HEAVY TRAFFIC REINFORCED COVERS
- STAINLESS STEEL CONSTRUCTION
- SEDIMENT BASKET
- INTEGRAL EXTENSION ___ INCHES
- INLET & OUTLET SIZE ___ INCHES
- DOUBLE WALL CONSTRUCTION
- LEAK DETECTION
- FILTER MEDIUM
- COALESCING PACK
- ANODES
- HOLD DOWN PADS
- ALUMINUM COVER
- NO HUB CONNECTION
- HUB CONNECTION

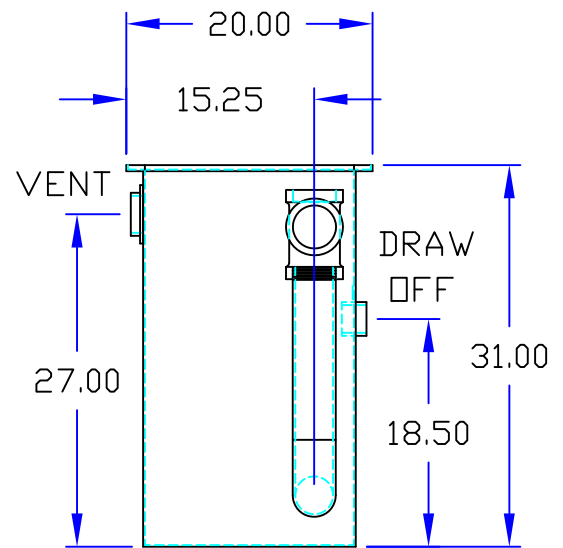
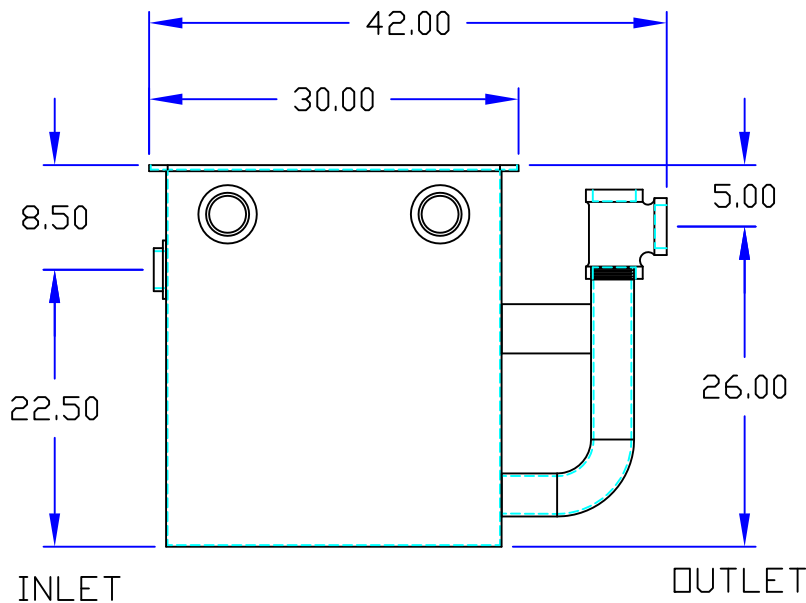

Specifications

Rockford Model OSL-5628 Oil/Water Separator all welded A36 10 ga steel, 35 g.p.m. intermittent flow, 64 gallon static capacity, 3.00" Threaded inlet and outlet, 3.00" threaded vent connections (2), 2.00" oil draw-off connection, visible double-wall outside trap seal, removable filter screen, non-removable separator plates, 3/16" nonskid diamond treadplate cover (for flush-with-floor installation) for pedestrian traffic secured with stainless steel bolts with heavy duty leakproof gasket, OPEX SHOP COAT coating inside & bituminous coating outside.

Optional features (Additional cost) listed above



Approved By

Company

Date