



Rockford Sanitary Systems, Inc.

ROCKFORD, IL 61125-0963

(815) 229-5077 - (800) 747-5077 - FAX (815) 229-5108

WEB SITE-www.rkfdseparators.com E MAIL-rssem@rkfdseparators.com

MODEL NO. OSL-5670

OIL/WATER SEPARATOR

DRAWN BY QUOTE #  
W.R.W.

JOB NAME

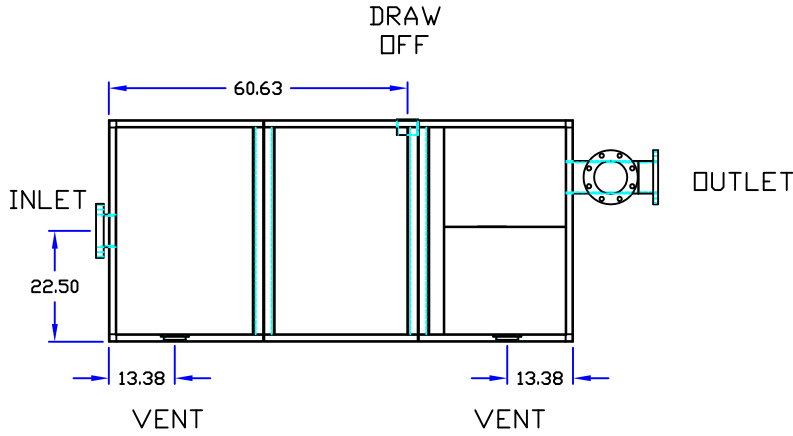

- OPTIONAL FEATURES (ADDITIONAL COST)
- ANCHOR FLANGE
  - RECESSED LIFT HANDLES \_\_\_ PER COVER
  - EPOXY COATING
  - LIGHT TRAFFIC REINFORCED COVERS
  - HEAVY TRAFFIC REINFORCED COVERS
  - STAINLESS STEEL CONSTRUCTION
  - SEDIMENT BASKET
  - INTEGRAL EXTENSION \_\_\_\_\_ INCHES
  - INLET & OUTLET SIZE \_\_\_\_\_ INCHES
  - DOUBLE WALL CONSTRUCTION
  - LEAK DETECTION
  - FILTER MEDIUM
  - COALESCING PACK
  - ANODES
  - HOLD DOWN PADS
  - ALUMINUM COVER
  - NO HUB CONNECTION
  - HUB CONNECTION

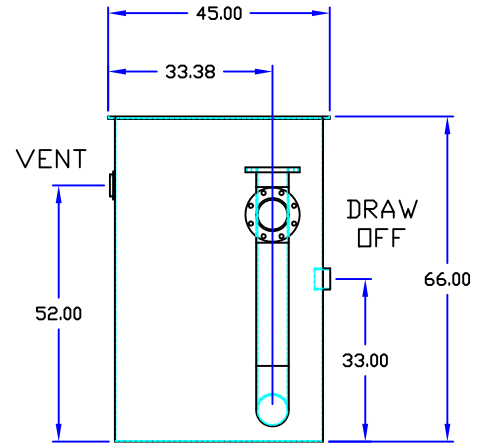
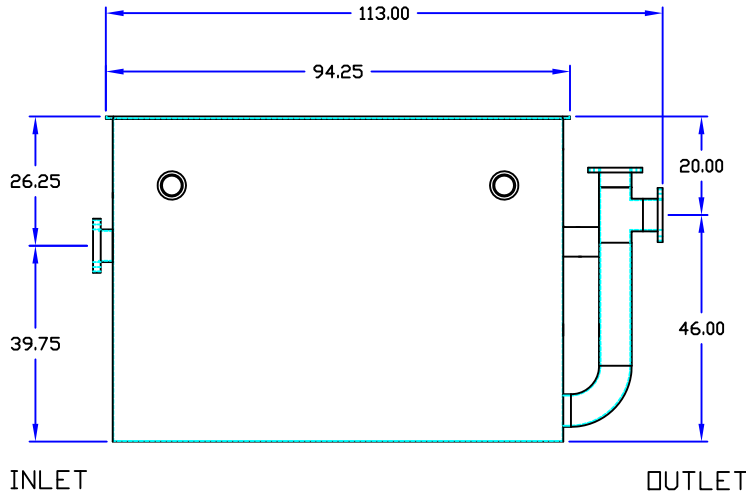

## Specifications

Rockford Model OSL-5670 Oil/Water Separator all welded A36 10ga. steel, 500 g.p.m. intermittent flow, 735 gallon static capacity, 6.00" Flanged inlet and outlet, 4.00" threaded vent connections (2), 3.00" oil draw-off connection, visible double-wall outside trap seal, removable filter screen, non-removable separator plates, 3/16" nonskid diamond treadplate cover (for flush-with-floor installation) for pedestrian traffic secured with stainless steel bolts with heavy duty leakproof gasket, OPEX SHOP COAT coating inside & bituminous coating outside.

Optional features (Additional cost) listed above



Approved By

Company

Date