



# ROCKFORD SEPARATORS

5159 28th Ave ROCKFORD, IL 61109  
 (815) 229-5077 - FAX (815) 229-5108  
 www.rkfdseparators.com - rssem@rkfdseparators.com

**MODEL NO. OST-5636-100**

**OIL / WATER SEPARATOR**

**DRAWN BY R.P.P.**

**QUOTE#:**

**DATE: 10/07/22**

**JOB NAME:**

OPTIONAL FEATURES (ADDITIONAL COST)

- ANCHOR FLANGE
- RECESSED LIFT HANDLES \_\_\_\_\_ PER COVER
- EPOXY COATING
- LIGHT TRAFFIC REINFORCED COVERS
- HEAVY TRAFFIC REINFORCED COVERS
- STAINLESS STEEL CONSTRUCTION
- SEDIMENT BASKET
- INTEGRAL EXTENSION \_\_\_\_\_ INCHES
- INLET & OUTLET SIZE \_\_\_\_\_ INCHES
- DOUBLE WALL CONSTRUCTION
- LEAK DETECTION
- FILTER MEDIUM
- COALESCING PACK
- ANODES
- HOLD DOWN PADS
- ALUMINUM COVER
- NO HUB CONNECTION
- HUB CONNECTION

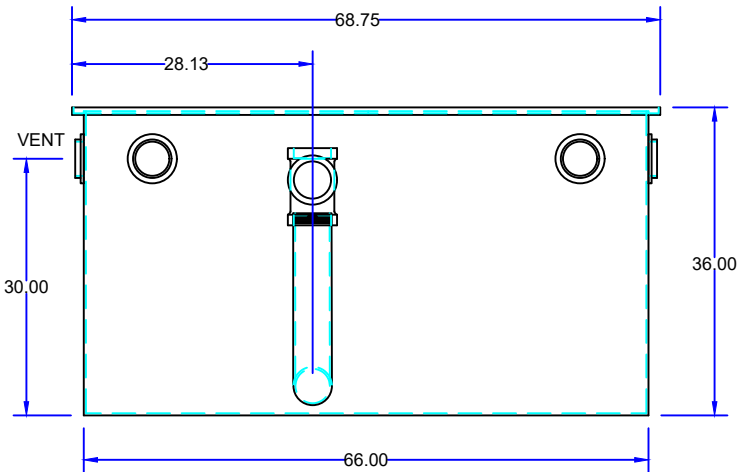
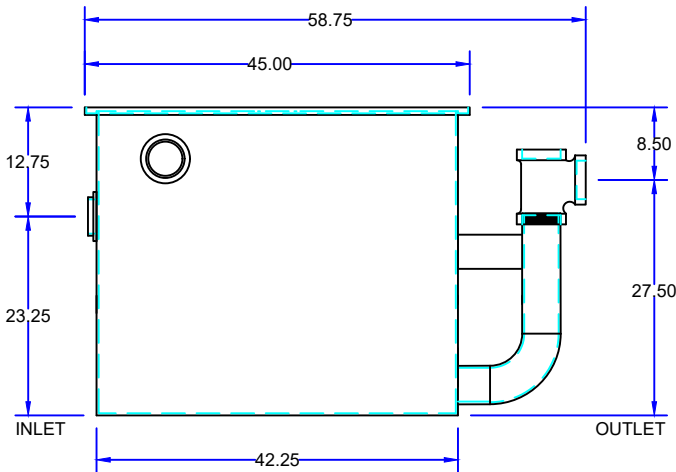
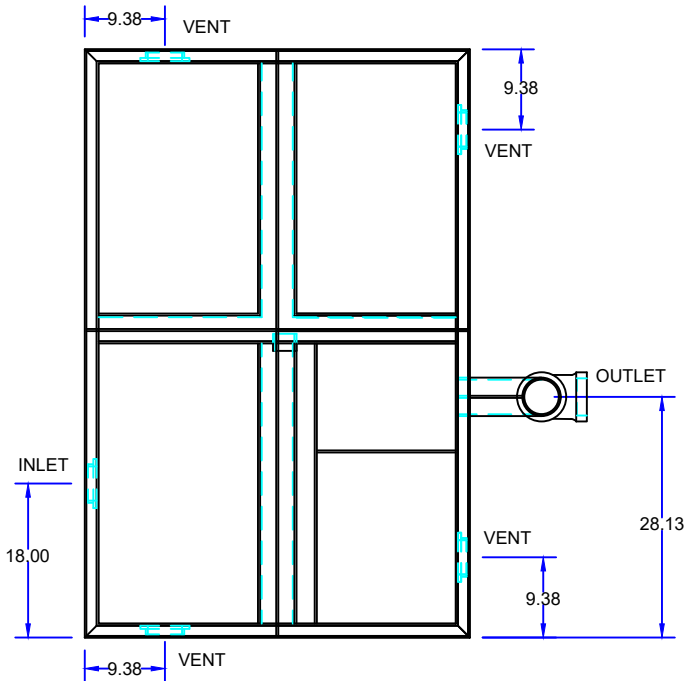

## SPECIFICATIONS

Rockford Model OST-5636-100 Oil/Water Separator all welded A36 1/4" steel, 75 g.p.m. intermittent flow, 150 gallon static capacity with 100 gallon waste oil storage, 4.00" threaded inlet/outlet & 4.00" threaded vent connections (4), visible double-wall outside trap seal, removable filter screen, non-removable separator screens, 3/8" nonskid tread plate covers (4) (for flush-with-floor installation) for pedestrian traffic secured with stainless steel bolts with heavy duty leak proof gasket, OPEX SHOP COAT coating inside & bituminous coating outside.

Optional features (Additional cost) listed above

**Approved By**

**Company**

**Date**