



Rockford Sanitary Systems, Inc.

ROCKFORD, IL 61125-0963

(815) 229-5077 - (800) 747-5077 - FAX (815) 229-5108

WEB SITE-www.rkfdseparators.com E MAIL-rssem@rkfdseparators.com

MODEL NO. OSTL-5628-50

OIL/WATER SEPARATOR

DRAWN BY  
W.R.W.

QUOTE #

JOB NAME

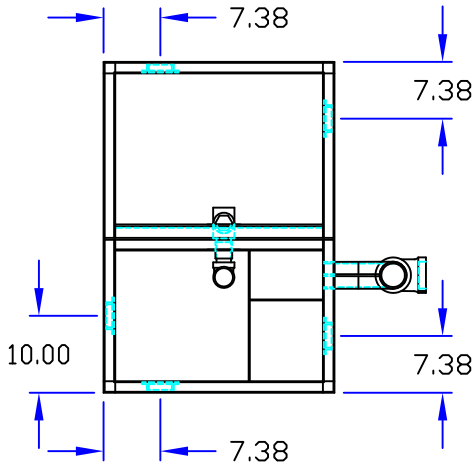

OPTIONAL FEATURES (ADDITIONAL COST)

- ANCHOR FLANGE
- FILTER MEDIUM
- RECESSED LIFT HANDLES IN COVERS
- EPOXY COATING
- ANODES
- REINFORCED COVERS \_\_\_\_\_ LOAD
- STAINLESS STEEL CONSTRUCTION
- SEDIMENT BASKET
- INTEGRAL EXTENSION \_\_\_\_\_ INCHES
- INLET & OUTLET SIZE \_\_\_\_\_ INCHES
- DOUBLE WALL CONSTRUCTION
- LEAK DETECTION
- HIGH LEVEL SENSOR & ALARM
- COALESCING PACK
- PUMP OUT CONNECTION

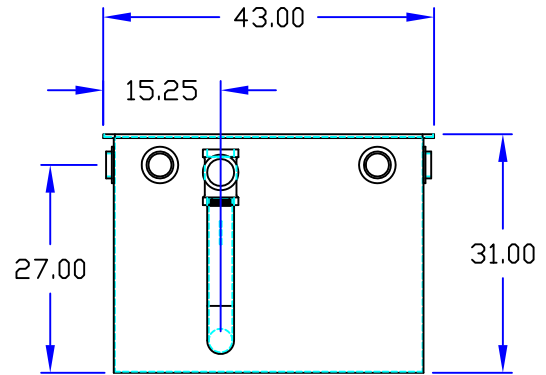
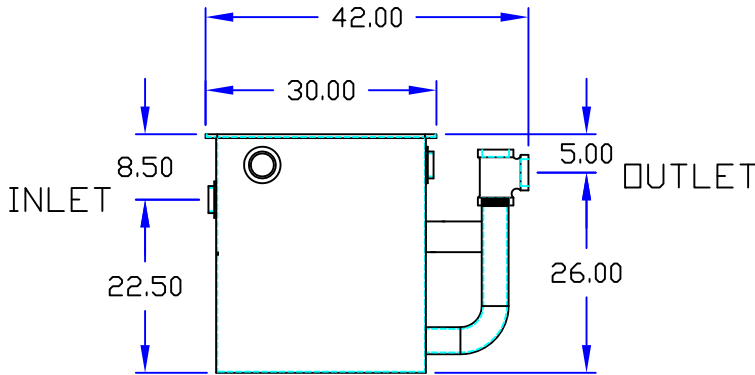

## Specifications

Rockford Model OSTL-5628-50 Oil/Water Separator all welded A36 10 ga steel, 35 g.p.m. intermittent flow, 64 gallon static capacity with 50 gallon waste oil storage, 3.00" threaded inlet/outlet & 3.00" threaded vent connections (4), visible double-wall outside trap seal, removable filter screen, non-removable separator screens, 3/16" nonskid tread-plate covers (2) (for flush-with-floor installation) for pedestrian traffic secured with stainless steel bolts with heavy duty leakproof gasket, DPEX SHOP COAT coating inside & bituminous coating outside.

Optional features (Additional cost) listed above



Approved By

Company

Date