



Rockford Sanitary Systems, Inc.

ROCKFORD, IL 61125-0963

(815) 229-5077 - (800) 747-5077 - FAX (815) 229-5108

WEB SITE-www.rkfdseparators.com E MAIL-rssem@rkfdseparators.com

MODEL NO. OSTL-5630-100

OIL/WATER SEPARATOR

DRAWN BY
W.R.W.

QUOTE #

JOB NAME

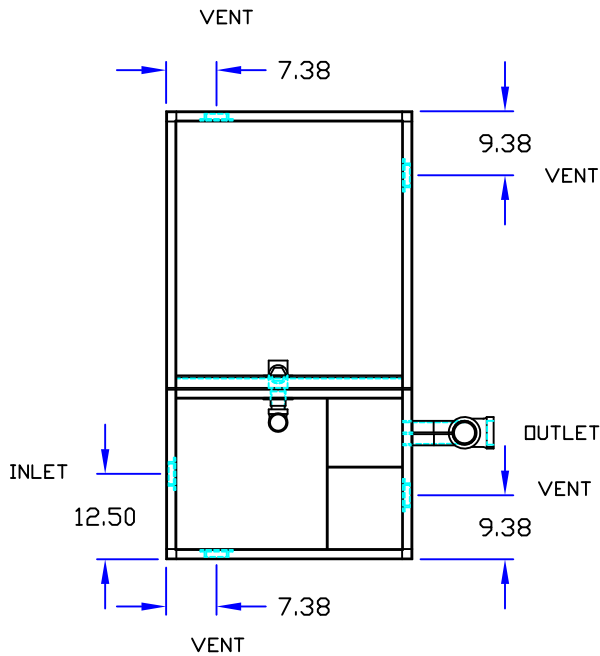

- OPTIONAL FEATURES (ADDITIONAL COST)
- ANCHOR FLANGE
 - FILTER MEDIUM
 - RECESSED LIFT HANDLES IN COVERS
 - EPOXY COATING
 - ANODES
 - REINFORCED COVERS _____ LOAD
 - STAINLESS STEEL CONSTRUCTION
 - SEDIMENT BASKET
 - INTEGRAL EXTENSION _____ INCHES
 - INLET & OUTLET SIZE _____ INCHES
 - DOUBLE WALL CONSTRUCTION
 - LEAK DETECTION
 - HIGH LEVEL SENSOR & ALARM
 - COALESCING PACK
 - PUMP OUT CONNECTION
 - HOLD DOWN PADS
 - STORAGE COMPARTMENT LADDER
 - ALUMINUM COVER
 - NO HUB CONNECTION
 - HUB CONNECTION

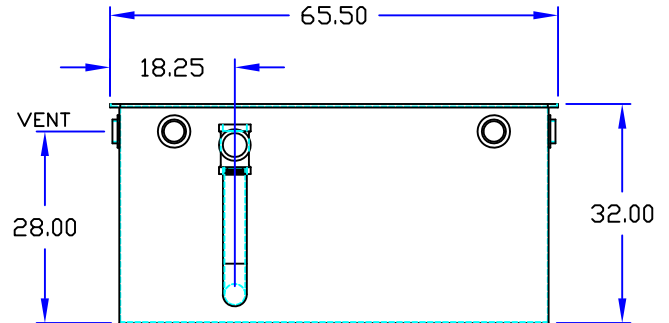
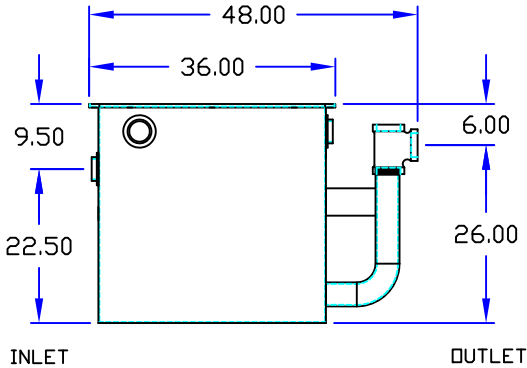

Specifications

Rockford Model OSTL-5630-100 Oil/Water Separator all welded 10ga HR steel, 50 g.p.m. intermittent flow, 75 gallon static capacity with 100 gallon waste oil storage, 3.00" threaded inlet/outlet & 3.00" threaded vent connections (4), visible double-wall outside trap seal, removable filter screen, non-removable separator screens, 3/16" nonskid treadplate covers (2) (for flush-with-floor installation) for pedestrian traffic secured with stainless steel bolts with heavy duty leakproof gasket, PEX SHOP COAT coating inside & bituminous coating outside.

Optional features (Additional cost) listed above

Approved By

Company

Date