



Rockford Sanitary Systems, Inc.

ROCKFORD, IL 61125-0963

(815) 229-5077 - (800) 747-5077 - FAX (815) 229-5108

WEB SITE-www.rkfdseparators.com E MAIL-rssem@rkfdseparators.com

MODEL NO. OSTL-5648-300

OIL/WATER SEPARATOR

DRAWN BY
W.R.W.

QUOTE #

JOB NAME

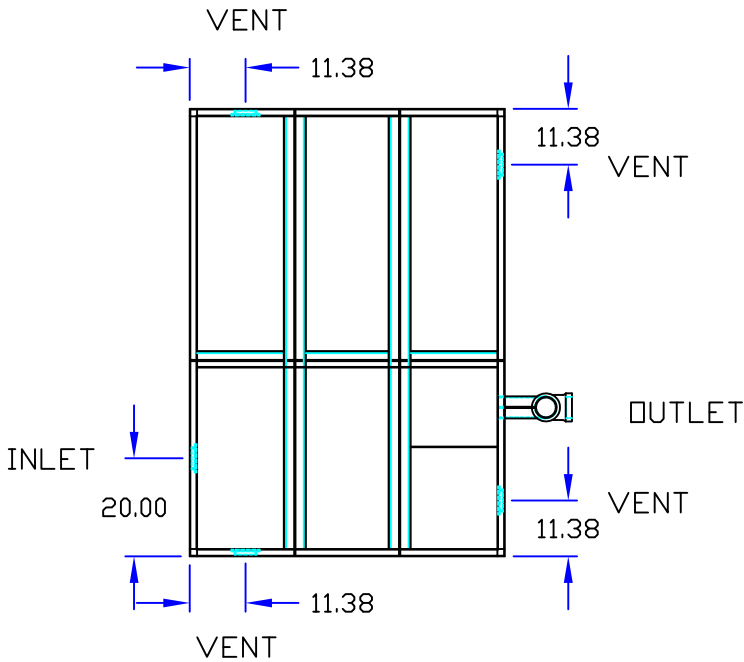

OPTIONAL FEATURES (ADDITIONAL COST)

- ANCHOR FLANGE
- FILTER MEDIUM
- RECESSED LIFT HANDLES IN COVERS
- EPOXY COATING
- ANODES
- REINFORCED COVERS _____ LOAD
- STAINLESS STEEL CONSTRUCTION
- SEDIMENT BASKET
- INTEGRAL EXTENSION _____ INCHES
- INLET & OUTLET SIZE _____ INCHES
- DOUBLE WALL CONSTRUCTION
- LEAK DETECTION
- HIGH LEVEL SENSOR & ALARM
- COALESCING PACK

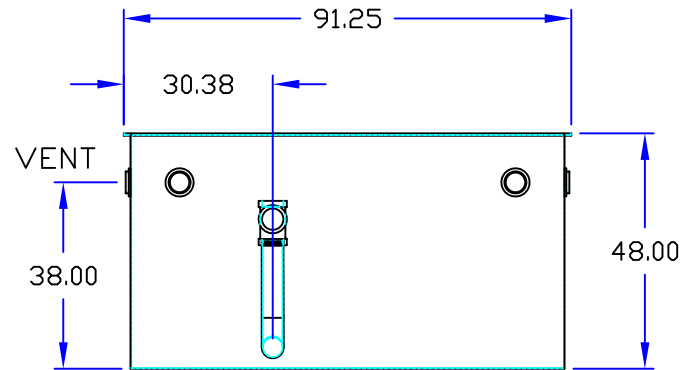
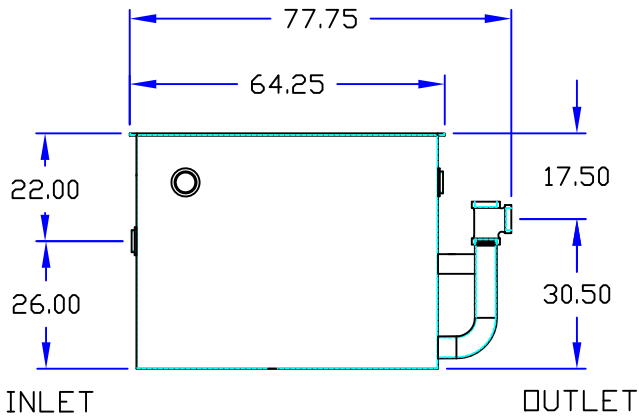

Specifications

Rockford Model OSTL-5648-300 Oil/Water Separator all welded A36 10ga. steel, 200 g.p.m. intermittent flow, 285 gallon static capacity with 300 gallon waste oil storage, 4.00" threaded inlet/outlet & 4.00" threaded vent connections (4), visible double-wall outside trap seal, removable filter screen, non-removable separator screens, 3/16" nonskid treadplate covers (6) (for flush-with-floor installation) for pedestrian traffic secured with stainless steel bolts with heavy duty leakproof gasket, PEX SHOP COAT coating inside & bituminous coating outside.

Optional features (Additional cost) listed above



Approved By

Company

Date