

# Rockford Separators

5159 28th Ave ROCKFORD, IL 61109

(815) 229-5077 - (800) 747-5077 - FAX (815) 229-5108

WEB SITE-www.rkfdseparators.com E MAIL-rssem@rkfdseparators.com

MODEL NO. ROI-250

OIL/SAND INTERCEPTOR

DRAWN BY

QUOTE #

W.R.W.

JOB NAME

Note; Standard unit shown with 6" riser.  
Manway height can be made to customers specified requirements.

### OPTIONAL FEATURES (ADDITIONAL COST)

- MANWAY HEIGHT REQUIRED \_\_\_\_\_ INCHES
- INLET & OUTLET SIZE \_\_\_\_\_ INCHES
- EPOXY COATING  ANODES
- STAINLESS STEEL CONSTRUCTION
- DOUBLE WALL CONSTRUCTION
- LEAK DETECTION
- HIGH LEVEL SENSOR & ALARM
- COALESCING PACK
- PUMP OUT CONNECTION
- HOLD DOWN PADS
- RECESSED LIFT HANDLES IN COVERS
- ANCHOR FLANGE

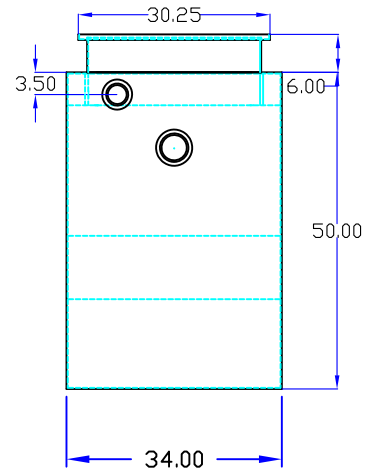
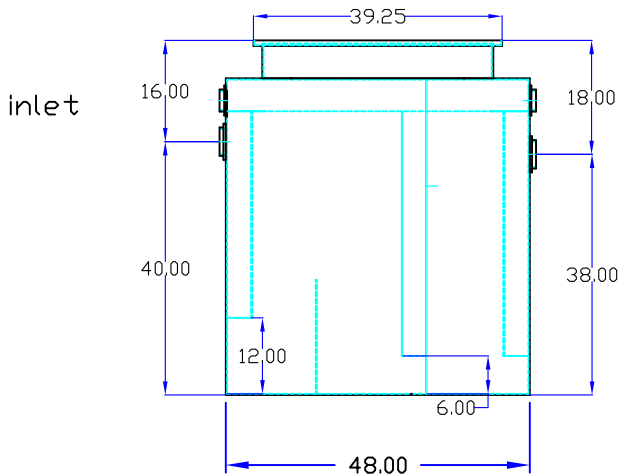
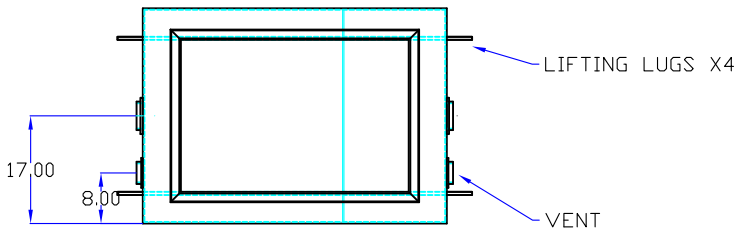

## Specifications

Rockford Model ROI-250 all welded steel gravity oil/sand interceptor, with 250 gallon capacity, with 150 gpm intermittent flow, 4" threaded inlet/outlet and 3" vent connections, removable 3/8" nonskid tread plate cover for flush with grade installation suitable for heavy traffic load (H/20), secured with stainless steel flat head screws, heavy duty leak-proof gasket, with bituminous coating outside. Supplied with lifting lugs X4. Approx. ship weight of 1100 Lbs. Unit is built to IAPMO/ANSI Z1001-2014 construction standard for fabricated gravity interceptors.

Optional features (Additional cost) listed above

Approved By

Company

Date