

Rockford Separators

5159 28th Ave ROCKFORD, IL 61109

(815) 229-5077 - (800) 747-5077 - FAX (815) 229-5108

WEB SITE-www.rkfdseparators.com E MAIL-rssem@rkfdseparators.com

MODEL NO. ROI-350

OIL/SAND INTERCEPTOR

DRAWN BY
W.R.W.

QUOTE #

JOB NAME

OPTIONAL FEATURES (ADDITIONAL COST)

Note; Standard unit shown with 6" riser.
Manway height can be made to customers specified requirements.

- MANWAY HEIGHT REQUIRED _____ INCHES
- INLET & OUTLET SIZE _____ INCHES
- EPOXY COATING ANODES
- STAINLESS STEEL CONSTRUCTION
- DOUBLE WALL CONSTRUCTION
- LEAK DETECTION
- HIGH LEVEL SENSOR & ALARM
- COALESCING PACK
- PUMP OUT CONNECTION
- HOLD DOWN PADS
- RECESSED LIFT HANDLES IN COVERS
- ANCHOR FLANGE

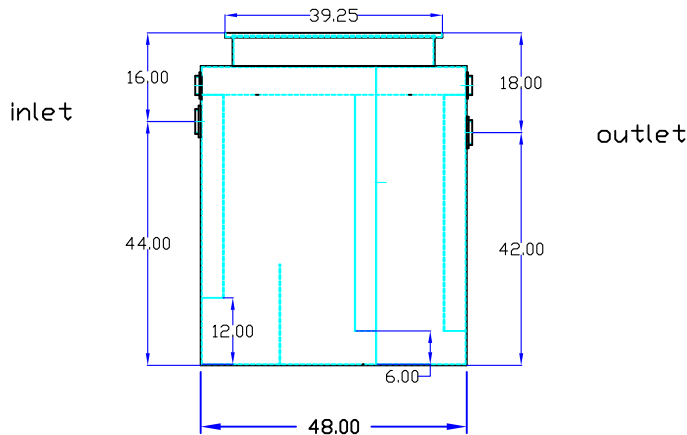
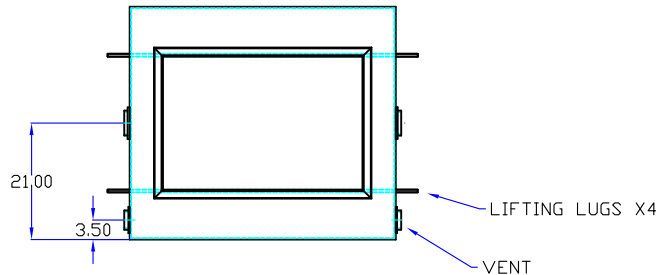

Specifications

Rockford Model ROI-350 all welded steel gravity oil/sand interceptor, with 350 gallon capacity, with 200 gpm intermittent flow, 4" threaded inlet/outlet and 3" vent connections, removable 3/8" nonskid tread plate cover for flush with grade installation suitable for heavy traffic load (H/20), secured with stainless steel flat head screws, heavy duty leak-proof gasket, with bituminous coating outside. Supplied with lifting lugs X4. Approx. ship weight of 1100 Lbs.

Unit built to IAPMO/ANSI Z1001-2014 construction standard for gravity grease/oil interceptors.

Optional features (Additional cost) listed above

Approved By

Company

Date