



Rockford Sanitary Systems, Inc.

ROCKFORD, IL 61125-0963

(815) 229-5077 - (800) 747-5077 - FAX (815) 229-5108

WEB SITE-www.rkfdseparators.com E MAIL-rssem@rkfdseparators.com

MODEL NO. RTO-20

GREASE SEPARATOR

DRAWN BY

QUOTE #

JOB NAME

W.R.W.

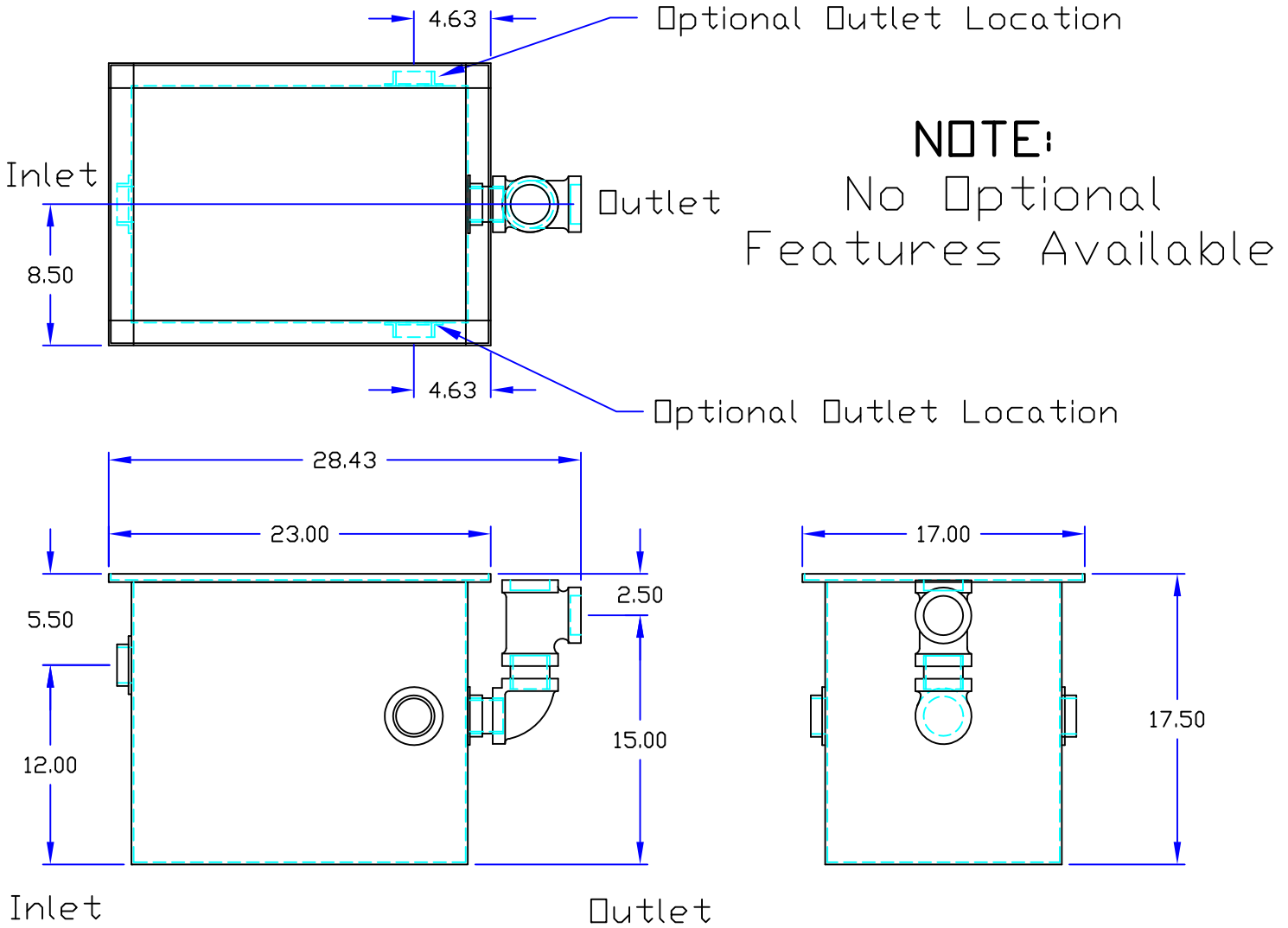

Specifications

Rockford Model RTO-20 all welded steel separator, 17 gallon static capacity, 20 g.p.m. intermittent flow, 2.00" tapped inlet and outlet connection, 70 lbs. greasy sludge capacity, visible double-wall outside trap seal, easily removable filter screen removable 3/16" nonskid diamond tread-plate cover for on the floor or flush in the floor installation suitable for pedestrian traffic, secured with stainless flat head screws, heavy duty leak-proof gasket, enamel coating inside and outside. Shipped with outlet fittings, & (2) plugs for unused optional outlet locations.



Approved By

Company

Date