



Rockford Sanitary Systems, Inc.

ROCKFORD, IL 61125-0963

(815) 229-5077 - (800) 747-5077 - FAX (815) 229-5108

WEB SITE-www.rkfdseparators.com E MAIL-rssem@rkfdseparators.com

MODEL NO. RTO-50-LO

GREASE SEPARATOR

DRAWN BY

QUOTE #

JOB NAME

W.R.W.

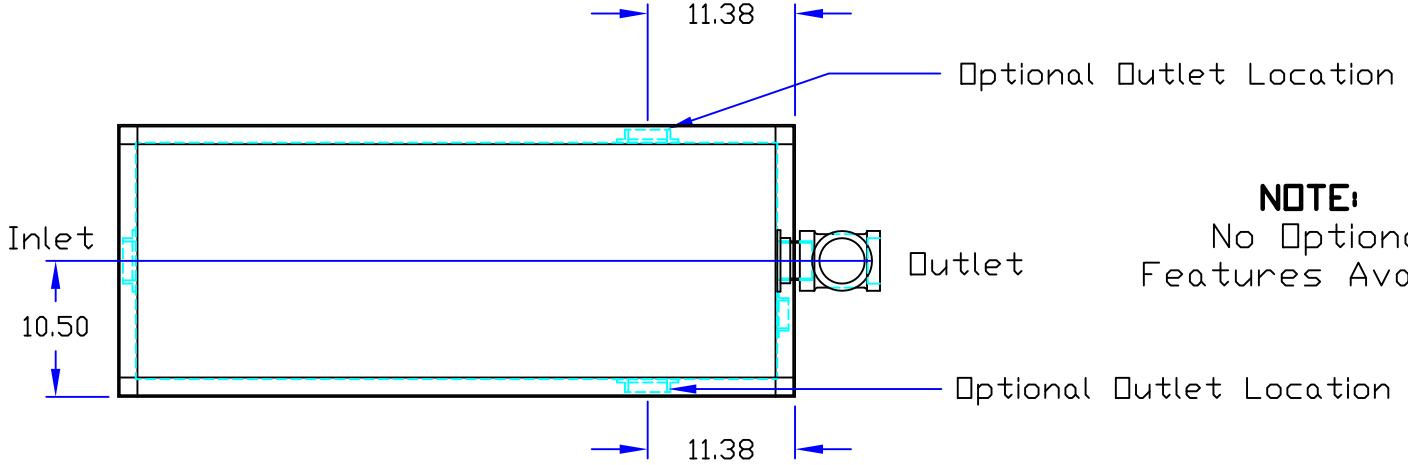

**NOTE:**  
No Optional  
Features Available

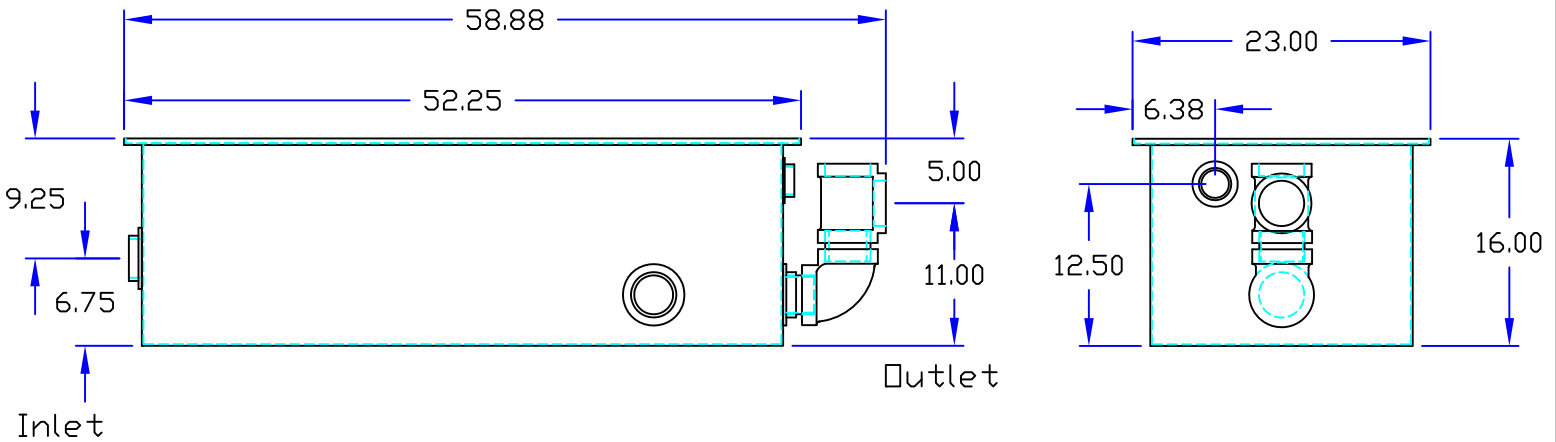

## Specifications

Rockford Model RTO-50-LO all welded steel separator, 41 gallon static capacity, 50 g.p.m. intermittent flow, 3.00" tapped inlet/outlet with 2.00" tapped internal vent connection, 250 lbs greasy sludge capacity, visible double-wall outside trap seal, separator plate and removeable filter screen, removeable 3/16" nonskid diamond tread-plate cover for flush with floor installation suitable for pedestrian traffic secured with stainless flat head screws, heavy duty leak-proof gasket, enamel coating inside and outside. Shipped with required outlet fittings, & (2) plugs for unused optional outlet locations.



Approved By

Company

Date