



ROCKFORD SEPARATORS

5159 28th Ave ROCKFORD, IL 61109
(815) 229-5077 - FAX (815) 229-5108
www.rkfdseparators.com - rssem@rkfdseparators.com

MODEL NO. RSP-1500-O

OIL/SAND INTERCEPTOR

DRAWN BY R.P.P.

QUOTE#:

DATE: 11/19/25

JOB NAME:

OPTIONAL FEATURES (ADDITIONAL COST)

- (3) CAST IRON H2O COVERS
- (3) HDPE MANWAY RISER KITS
- (8) TIE-DOWN ANCHOR BRACKETS
- ALTERNATE INLET & OUTLET SIZE ____ INCHES
- HIGH LEVEL INTERFACE SENSOR W/ 1 ALARM PANEL

NOTE: FOR HIGH WATER TABLE APPLICATIONS ADD ANCHOR BRACKETS TO BE ANCHORED TO ANTI-FLOAT SLAB (ANTI-FLOAT SLAB BY OTHERS)

NOTE: UPWARD GROUNDWATER PRESSURE WILL REQUIRE A WATER TIGHT CONCRETE VAULT (CONCRETE VAULT BY OTHERS).

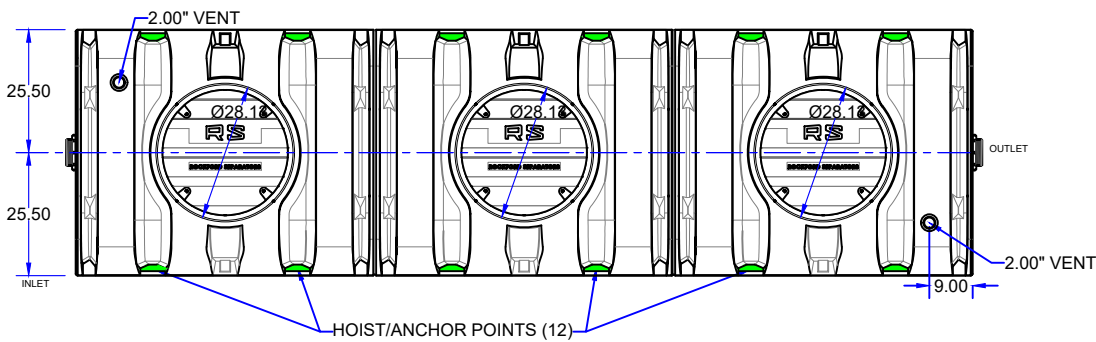

NOTE: STANDARD COVER INSERT MAY BE EXTENDED UP TO AN ADDITIONAL 9.00"

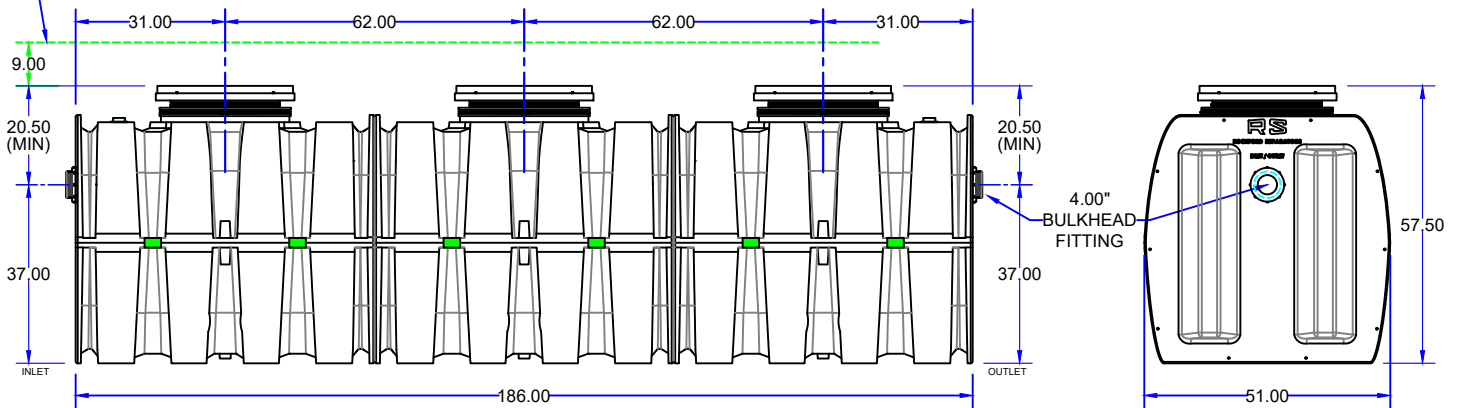

SPECIFICATIONS

Rockford Separators Model RSP-1500-O high density polyethylene gravity oil/sand interceptor, rotationally molded 3/8" HDPE wall, with 1500 gallon capacity, 1500 gpm intermittent flow, 4.00" threaded inlet/outlet, (2) 2.00" vent connections (must use one and cap the other), removable HDPE cover for flush with grade installation suitable for pedestrian traffic load (1000#), secured with stainless steel HEX head bolts, heavy duty leak-proof gasket, 12 lifting/anchor points (8 to be used), and Limited Lifetime Warranty. Approximate ship weight of 990 Lbs.

Optional features (Additional cost) listed above

Approved By

Company

Date