



ROCKFORD SEPARATORS

5159 28th Ave ROCKFORD, IL 61109
(815) 229-5077 - FAX (815) 229-5108
www.rkfdseparators.com - rssem@rkfdseparators.com

MODEL NO. RSP-20-G

GREASE INTERCEPTOR

DRAWN BY R.P.P.

QUOTE#:

DATE: 01/30/26

JOB NAME:

OPTIONAL FEATURES (ADDITIONAL COST)

- (1) CAST IRON H2O COVER
- (1) 36" HDPE ACCESS RISER KIT
- (2) TIE-DOWN ANCHOR STRAPS
- ALTERNATE INLET & OUTLET SIZE ____ INCHES
- 2.00" PUMP-OUT PORT

CURRENTLY NOT AVAILABLE

NOTE: FOR HIGH WATER TABLE APPLICATIONS ADD ANCHOR BRACKETS TO BE ANCHORED TO ANTI-FLOAT SLAB (ANTI-FLOAT SLAB BY OTHERS)

NOTE: UPWARD GROUNDWATER PRESSURE WILL REQUIRE A WATER TIGHT CONCRETE VAULT (CONCRETE VAULT BY OTHERS).

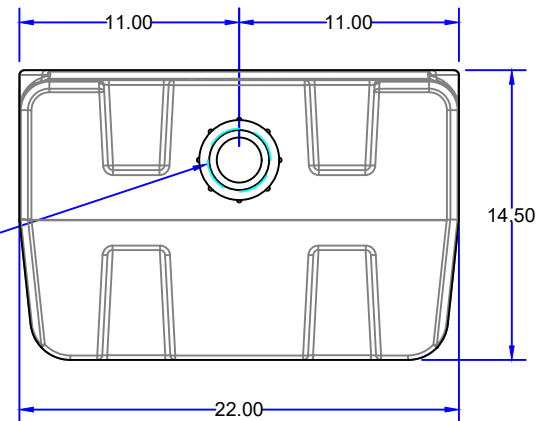
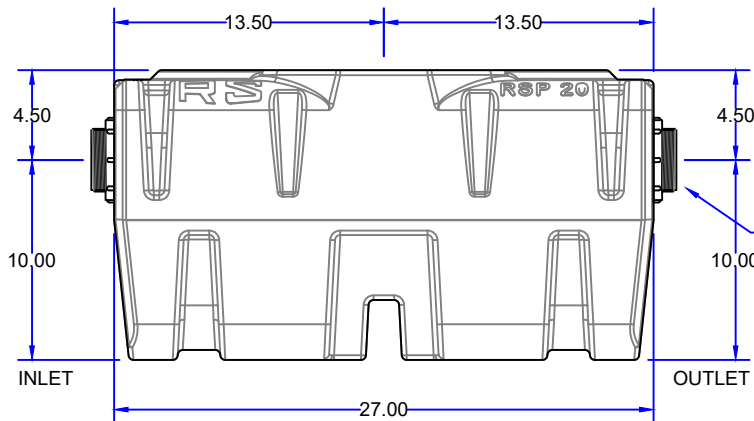
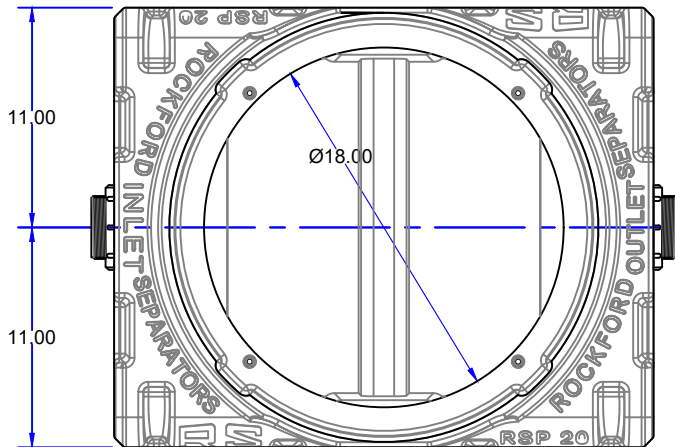

NOTE: MANUFACTURE RECOMMENDED DOWNSTREAM VENT TO PREVENT AIR-BOUND LOCK, SIPHONAGE, AND ODORS. (FOR DETAILED REQUIREMENTS, CONTACT YOUR LOCAL CODE ENFORCEMENT OFFICIAL.)

SPECIFICATIONS

Rockford Separators Model RSP-20-G high density polyethylene gravity grease interceptor, rotationally molded 3/8" HDPE wall, with 2.00" threaded inlet/outlet, 20 gallon capacity, 20 gpm intermittent flow, 40 LBS greasy sludge capacity, removable HDPE cover for flush with grade installation suitable for pedestrian traffic load (1000#), secured with stainless steel HEX head bolts, heavy duty leak-proof gasket, and Limited Lifetime Warranty. Approximate ship weight of 40 Lbs.

Optional features (Additional cost) listed above

Approved By

Company

Date