



# ROCKFORD SEPARATORS

5159 28th Ave ROCKFORD, IL 61109  
 (815) 229-5077 - FAX (815) 229-5108  
 www.rkfdseparators.com - rssem@rkfdseparators.com

**MODEL NO. RSP-300-O**

**OIL/SAND INTERCEPTOR**

**DRAWN BY R.P.P.**

**QUOTE#:**

**DATE: 11/19/25**

**JOB NAME:**

**NOTE: FOR HIGH WATER TABLE APPLICATIONS ADD ANCHOR BRACKETS TO BE ANCHORED TO ANTI-FLOAT SLAB (ANTI-FLOAT SLAB BY OTHERS)**

**NOTE: UPWARD GROUNDWATER PRESSURE WILL REQUIRE A WATER TIGHT CONCRETE VAULT (CONCRETE VAULT BY OTHERS).**

OPTIONAL FEATURES (ADDITIONAL COST)

- (2) CAST IRON H2O COVERS
- (2) HDPE MANWAY RISER KITS
- (6) TIE-DOWN ANCHOR BRACKETS
- ALTERNATE INLET & OUTLET SIZE \_\_\_\_ INCHES
- HIGH LEVEL INTERFACE SENSOR W/ 1 ALARM PANEL

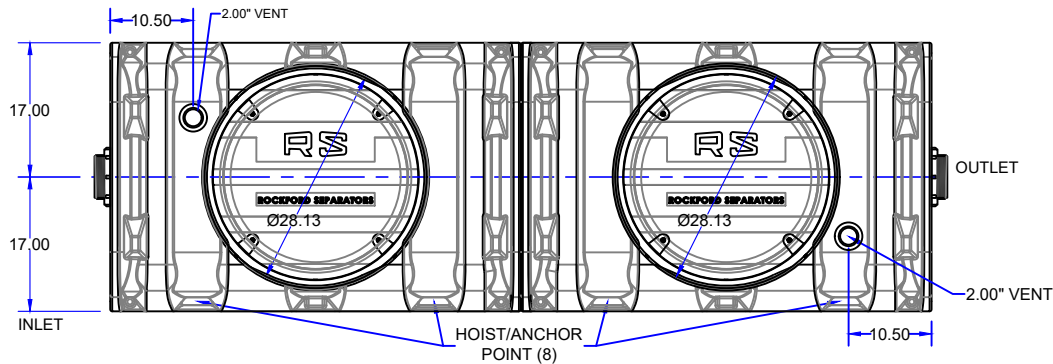

**NOTE: STANDARD COVER INSERT MAY BE EXTENDED UP TO AN ADDITIONAL 9.00"**

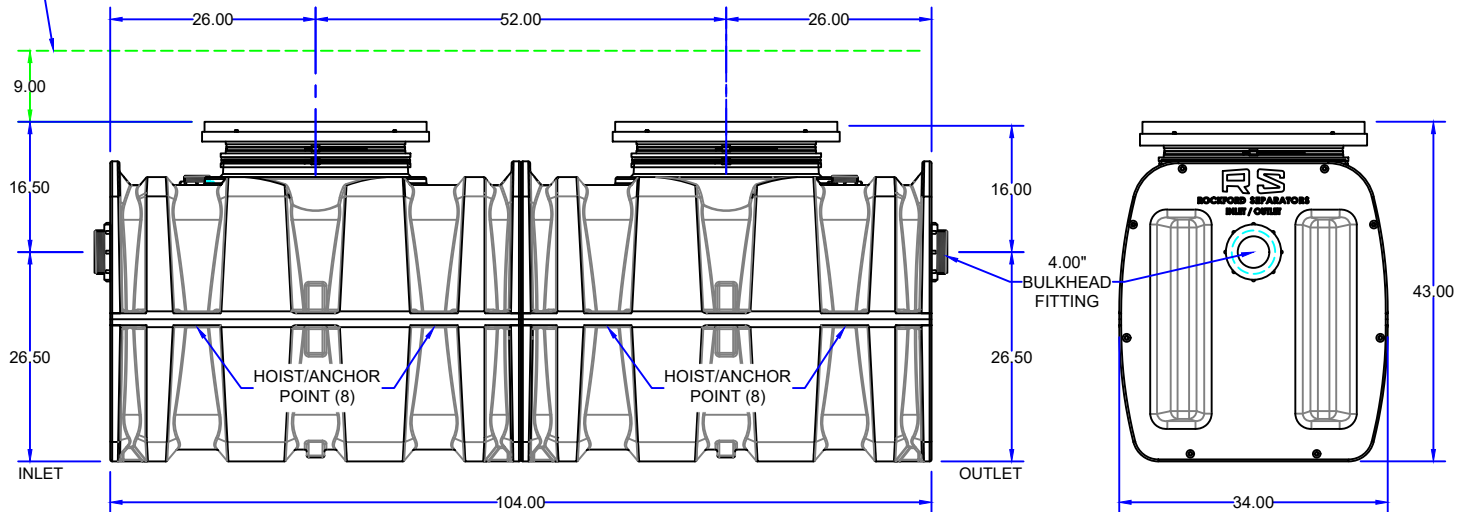

## SPECIFICATIONS

Rockford Separators Model RSP-300-O high density polyethylene gravity oil / sand interceptor, rotationally molded 3/8" HDPE wall, with 150 gallon capacity, 300 gpm intermittent flow, 4.00" threaded inlet/outlet, (2) 2.00" vent connections (must use one and cap the other), removable cover for flush with grade installation suitable for pedestrian traffic load (1000#), secured with stainless steel HEX head bolts, heavy duty leak-proof gasket, 8 lifting/anchor points (6 to be used), and Limited Lifetime Warranty. Approximate ship weight of 300 Lbs.

**Optional features (Additional cost) listed above**

**Approved By**

**Company**

**Date**