



ROCKFORD SEPARATORS

5159 28th Ave ROCKFORD, IL 61109
(815) 229-5077 - FAX (815) 229-5108
www.rkfdseparators.com - rssem@rkfdseparators.com

MODEL NO. RSP-50-O

OIL / SAND INTERCEPTOR

DRAWN BY R.P.P.

QUOTE#:

DATE: 02/19/26

JOB NAME:

OPTIONAL FEATURES (ADDITIONAL COST)

- (1) CAST IRON H2O COVER
- (1) 36" HDPE ACCESS RISER KIT
- (2) TIE-DOWN ANCHOR STRAPS
- ALTERNATE INLET & OUTLET SIZE ____ INCHES
- 2.00" PUMP-OUT PORT

CURRENTLY NOT AVAILABLE

NOTE: FOR HIGH WATER TABLE APPLICATIONS ADD ANCHOR BRACKETS TO BE ANCHORED TO ANTI-FLOAT SLAB (ANTI-FLOAT SLAB BY OTHERS)

NOTE: UPWARD GROUNDWATER PRESSURE WILL REQUIRE A WATER TIGHT CONCRETE VAULT (CONCRETE VAULT BY OTHERS).

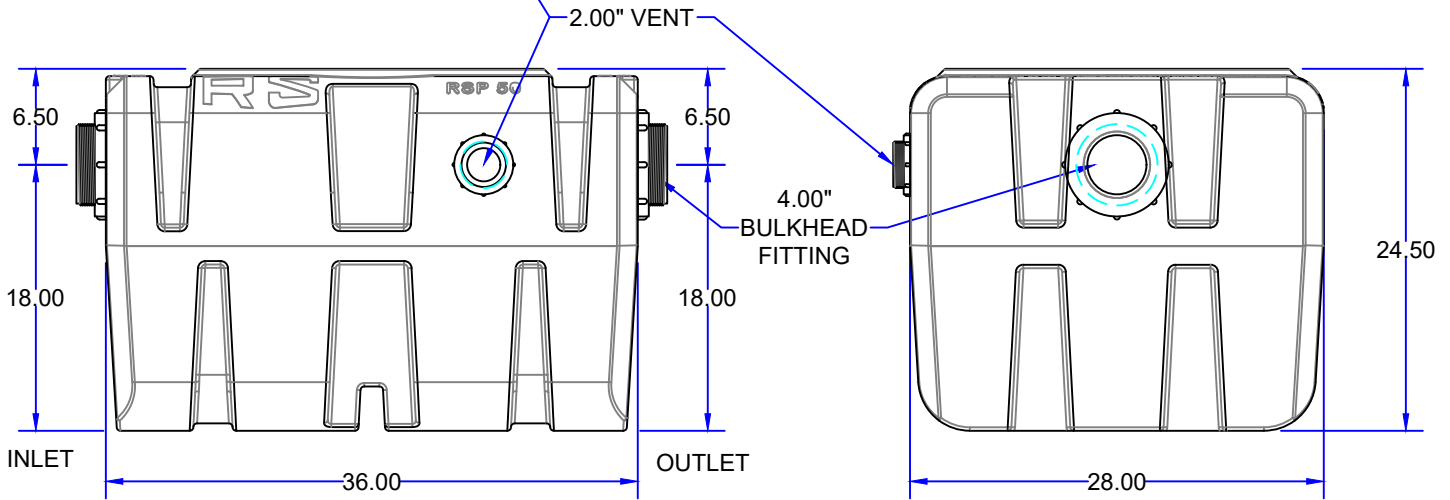
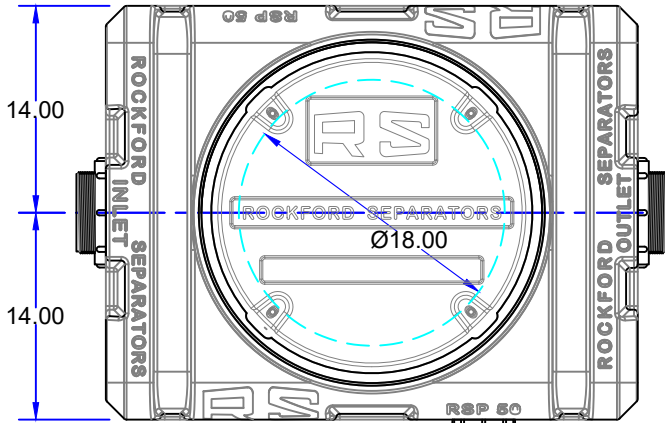

SPECIFICATIONS

Rockford Separators Model RSP-50-O high density polyethylene gravity oil/sand interceptor, rotationally molded 3/8" HDPE wall, with 50 gallon capacity, 50 gpm intermittent flow, 4.00" threaded inlet/outlet, (1) 2.00" vent connection, removable HDPE cover (1000 LB Load) for flush with grade installation suitable for pedestrian traffic load (1000#), secured with stainless steel HEX head bolts, heavy duty leak-proof gasket, and Limited Lifetime Warranty. Approximate ship weight of 60 Lbs.

Optional features (Additional cost) listed above

Approved By

Company

Date