



# ROCKFORD SEPARATORS

5159 28th Ave ROCKFORD, IL 61109  
(815) 229-5077 - FAX (815) 229-5108  
www.rkfdseparators.com - rssem@rkfdseparators.com

MODEL NO. RSP-150-G

GREASEINTERCEPTOR

DRAWN BY R.P.P.

QUOTE#:

DATE: 04/24/26

JOB NAME:

### OPTIONAL FEATURES (ADDITIONAL COST)

- (1) CAST IRON H2O COVER
- (1) HDPE MANWAY RISER KIT
- (4) TIE-DOWN ANCHOR STRAPS
- ALTERNATE INLET & OUTLET SIZE \_\_\_\_ INCHES
- GREASE MONITOR SYSTEM
- (1) 2.00" REMOTE PUMP-OUT PORT

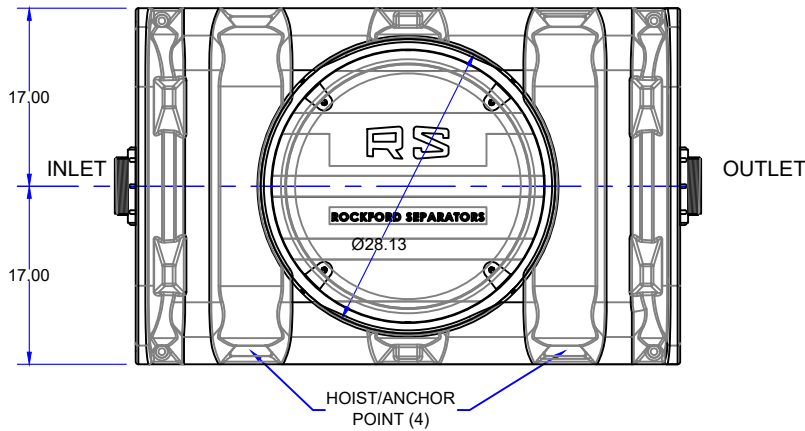

NOTE: STANDARD COVER INSERT MAY BE EXTENDED UP TO AN ADDITIONAL 9.00"

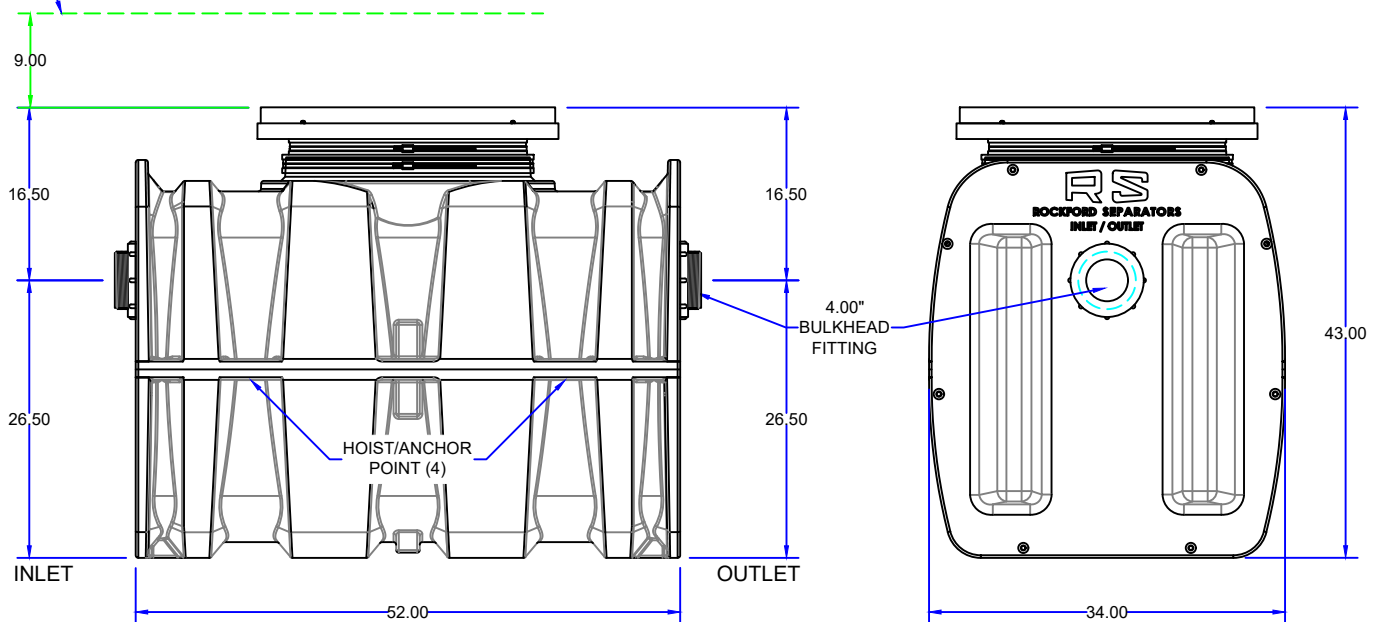

NOTE: For high water table applications add anchor brackets to be anchored to anti-float slab (anti-float slab by others). Upward groundwater pressure will require a water tight concrete vault (concrete vault by others).

## SPECIFICATIONS

Rockford Separators Model RSP-150-G high density polyethylene gravity grease interceptor, rotationally molded 3/8" HDPE wall, with 150 gallon capacity, 150 gpm intermittent flow, 300 pounds rated / 870 LBS actual greasy sludge capacity, 4.00" threaded inlet/outlet, removable HDPE cover for flush with grade installation suitable for pedestrian traffic load (500#), secured with stainless steel HEX head bolts, heavy duty leak-proof gasket, 4 lifting/tie-down points, and Limited Lifetime Warranty. Approximate ship weight of 150 Lbs.

Optional features (Additional cost) listed above

Approved By

Company

Date