



# ROCKFORD SEPARATORS

5159 28th Ave ROCKFORD, IL 61109  
 (815) 229-5077 - FAX (815) 229-5108  
 www.rkfdseparators.com - rssem@rkfdseparators.com

**MODEL NO. RSP-1500-G**

**GREASE INTERCEPTOR**

**DRAWN BY R.P.P.**

**QUOTE#:**

**DATE: 04/24/26**

**JOB NAME:**

OPTIONAL FEATURES (ADDITIONAL COST)

- (3) CAST IRON H2O COVERS
- (3) HDPE MANWAY RISER KITS
- (8) TIE-DOWN ANCHOR BRACKETS
- ALTERNATE INLET & OUTLET SIZE \_\_\_\_ INCHES
- GREASE MONITOR SYSTEM
- (3) 2.00" REMOTE PUMP-OUT PORT

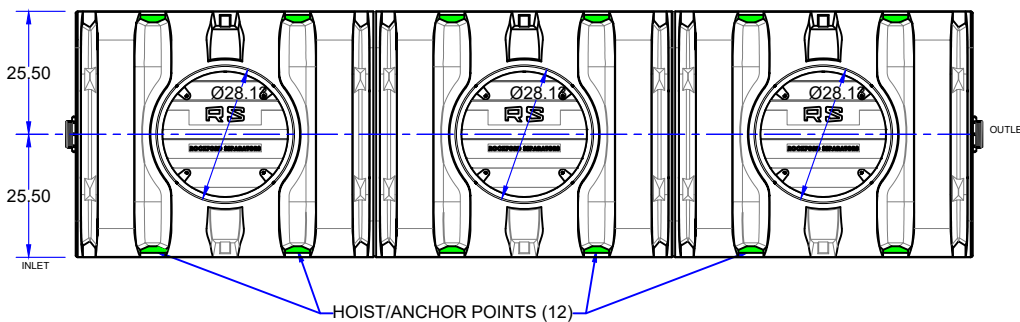

**NOTE: STANDARD COVER INSERT MAY BE EXTENDED UP TO AN ADDITIONAL 9.00"**

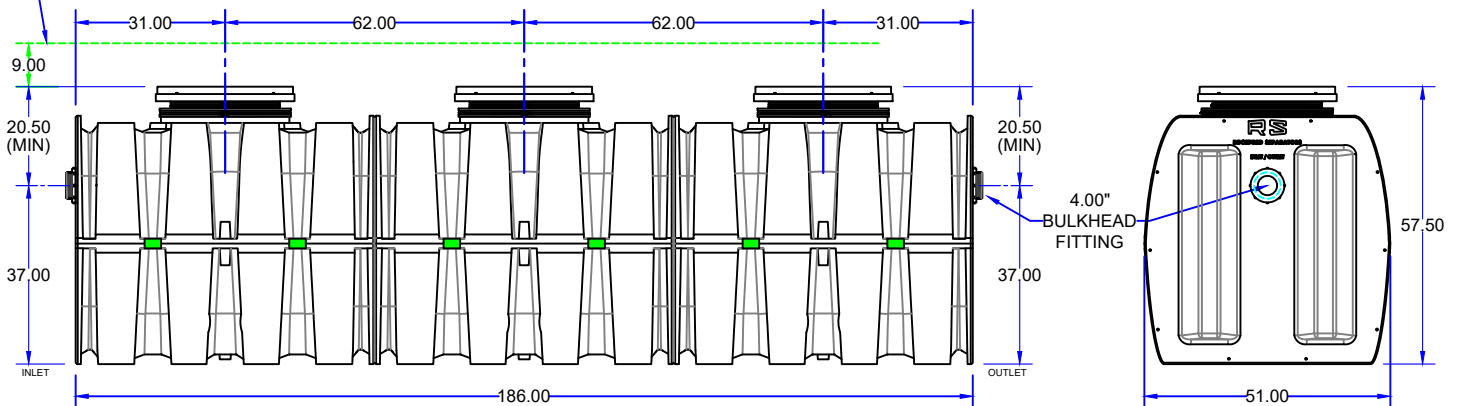

*NOTE: For high water table applications add anchor brackets to be anchored to anti-float slab (anti-float slab by others). Upward groundwater pressure will require a water tight concrete vault (concrete vault by others).*

## SPECIFICATIONS

Rockford Separators Model RSP-1500-G high density polyethylene gravity grease interceptor, rotationally molded 3/8" HDPE wall, with 1500 gallon capacity, 1500 gpm intermittent flow, 3,000 pounds rated / 8700 LBS actual greasy sludge capacity, 4.00" threaded inlet/outlet, (3) removable HDPE cover for flush with grade installation suitable for pedestrian traffic load (500#), secured with stainless steel HEX head bolts, heavy duty leak-proof gasket, 12 lifting/anchor points (8 to be used), and Limited Lifetime Warranty. Approximate ship weight of 990 Lbs.

**Optional features (Additional cost) listed above**

**Approved By**

**Company**

**Date**