



ROCKFORD SEPARATORS

5159 28th Ave ROCKFORD, IL 61109
(815) 229-5077 - FAX (815) 229-5108
www.rkfdseparators.com - rssem@rkfdseparators.com

MODEL NO. RSP-1000-G

GREASE INTERCEPTOR

DRAWN BY R.P.P.

QUOTE#:

DATE: 04/24/26

JOB NAME:

OPTIONAL FEATURES (ADDITIONAL COST)

- (2) CAST IRON H2O COVERS
- (2) HDPE MANWAY RISER KITS
- (6) TIE-DOWN ANCHOR BRACKETS
- ALTERNATE INLET & OUTLET SIZE ____ INCHES
- GREASE MONITOR SYSTEM
- (2) 2.00" REMOTE PUMP-OUT PORT

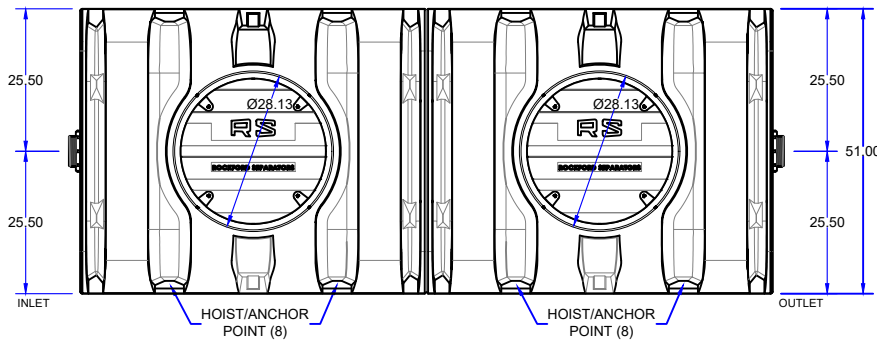

NOTE: STANDARD COVER INSERT MAY BE EXTENDED UP TO AN ADDITIONAL 9.00"

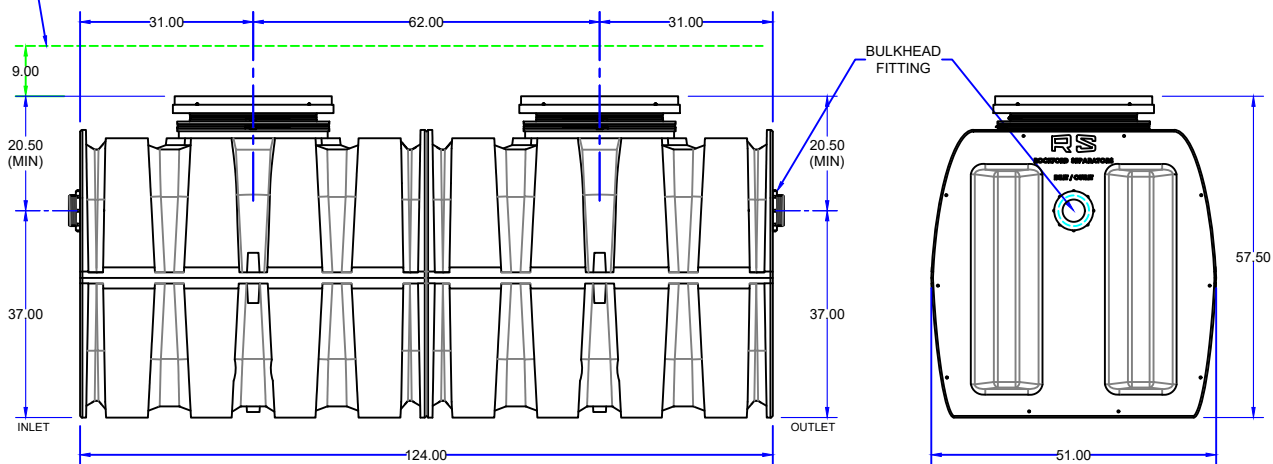

NOTE: For high water table applications add anchor brackets to be anchored to anti-float slab (anti-float slab by others). Upward groundwater pressure will require a water tight concrete vault (concrete vault by others).

SPECIFICATIONS

Rockford Separators Model RSP-1000-G high density polyethylene gravity grease interceptor, rotationally molded 3/8" HDPE wall, with 1000 gallon capacity, 1000 gpm intermittent flow, 2,000 pounds rated / 5,800 LBS actual greasy sludge capacity, 4.00" threaded inlet/outlet, removable HDPE cover for flush with grade installation suitable for pedestrian traffic load (500#), secured with stainless steel HEX head bolts, heavy duty leak-proof gasket, 8 lifting/anchor points (6 to be used), and Limited Lifetime Warranty. Approximate ship weight of 660 Lbs.

***NOTE: manufactured in the United States with domestic component content exceeding the current threshold required by BABAA.



Optional features (Additional cost) listed above

Approved By

Company

Date