



ROCKFORD SEPARATORS

5159 28th Ave ROCKFORD, IL 61109
(815) 229-5077 - FAX (815) 229-5108
www.rkfdseparators.com - rssem@rkfdseparators.com

MODEL NO. RSP-150-O

OIL/SAND INTERCEPTOR

DRAWN BY R.P.P.

QUOTE#:

DATE: 11/19/25

JOB NAME:

OPTIONAL FEATURES (ADDITIONAL COST)

- (1) CAST IRON H2O COVERS
- (1) HDPE MANWAY RISER KITS
- (4) TIE-DOWN ANCHOR BRACKETS
- ALTERNATE INLET & OUTLET SIZE ____ INCHES
- HIGH LEVEL INTERFACE SENSOR W/ 1 ALARM PANEL
- (1) REMOTE PUMP-OUT CONNECTION

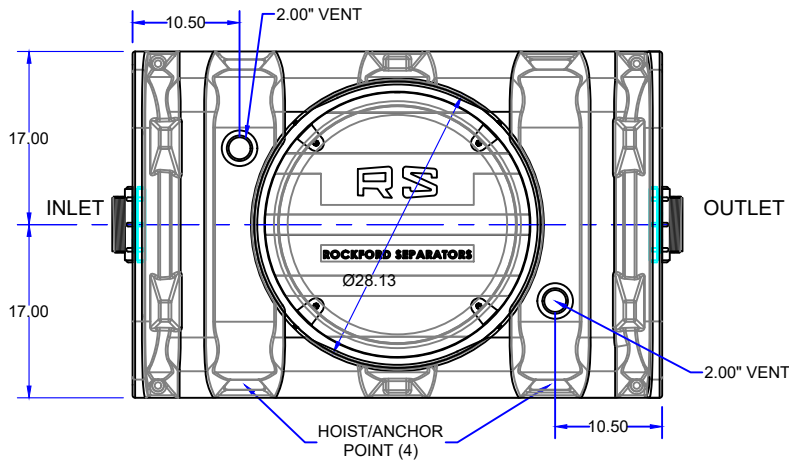

NOTE: STANDARD COVER INSERT MAY BE EXTENDED UP TO AN ADDITIONAL 9.00"

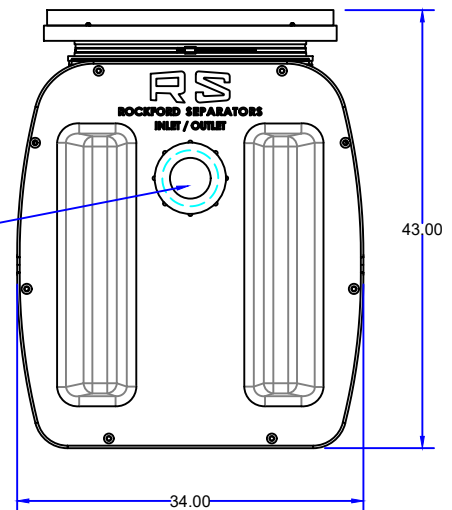
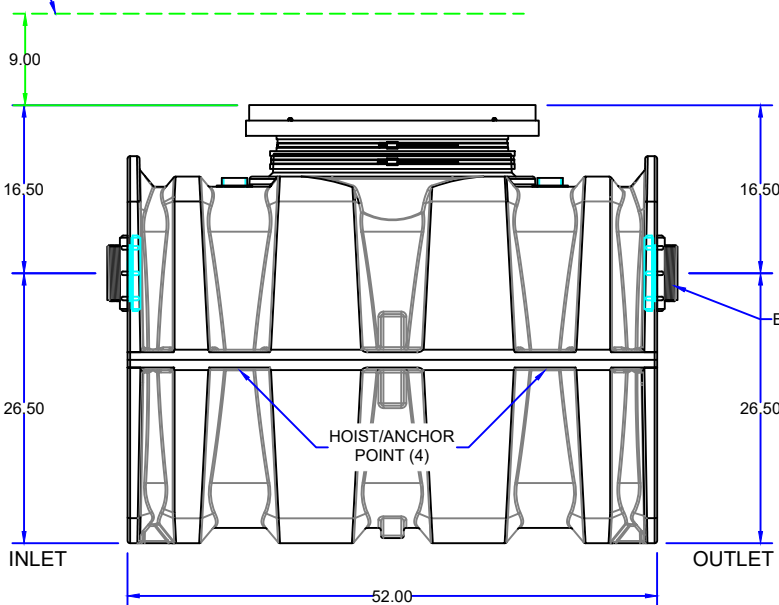

NOTE: For high water table applications add anchor brackets to be anchored to anti-float slab (anti-float slab by others). Upward groundwater pressure will require a water tight concrete vault (concrete vault by others).

SPECIFICATIONS

Rockford Separators Model RSP-150-O high density polyethylene gravity oil/sand interceptor, rotationally molded 3/8" HDPE wall, with 150 gallon capacity, 150 gpm intermittent flow, 4.00" threaded inlet/outlet, (2) 2.00" threaded vent connections (must use one and cap the other), removable HDPE cover for flush with grade installation suitable for pedestrian traffic load (500#), secured with stainless steel HEX head bolts, heavy duty leak-proof gasket, 4 lifting/tie-down points, and Limited Lifetime Warranty. Approximate ship weight of 150 Lbs.

***NOTE: manufactured in the United States with domestic component content exceeding the current threshold required by BABAA.



Optional features (Additional cost) listed above

Approved By

Company

Date