



# ROCKFORD SEPARATORS

5159 28th Ave ROCKFORD, IL 61109  
(815) 229-5077 - FAX (815) 229-5108  
www.rkfdseparators.com - rssem@rkfdseparators.com

MODEL NO. RSP-500-O

OIL/SAND INTERCEPTOR

DRAWN BY R.P.P.

QUOTE#:

DATE: 04/14/26

JOB NAME:

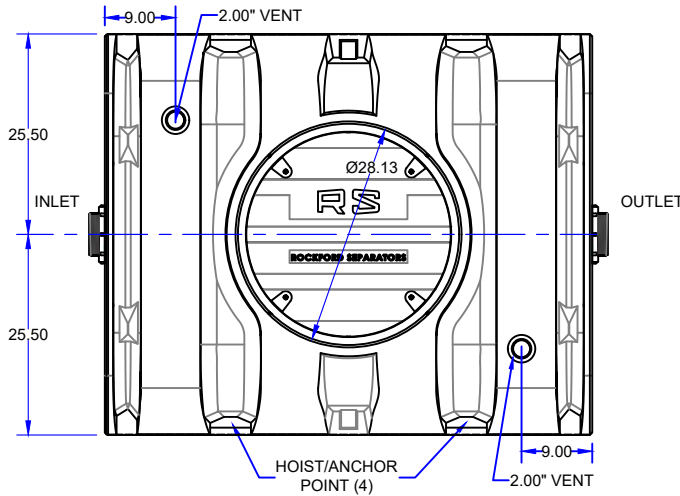

### OPTIONAL FEATURES (ADDITIONAL COST)

- (1) CAST IRON H2O COVER
- (1) HDPE MANWAY RISER KIT
- (4) TIE-DOWN ANCHOR BRACKETS
- ALTERNATE INLET & OUTLET SIZE \_\_\_\_ INCHES
- HIGH LEVEL INTERFACE SENSOR W/ 1 ALARM PANEL
- (1) REMOTE PUMP-OUT CONNECTION

NOTE: STANDARD COVER INSERT MAY BE EXTENDED UP TO AN ADDITIONAL 9.00"

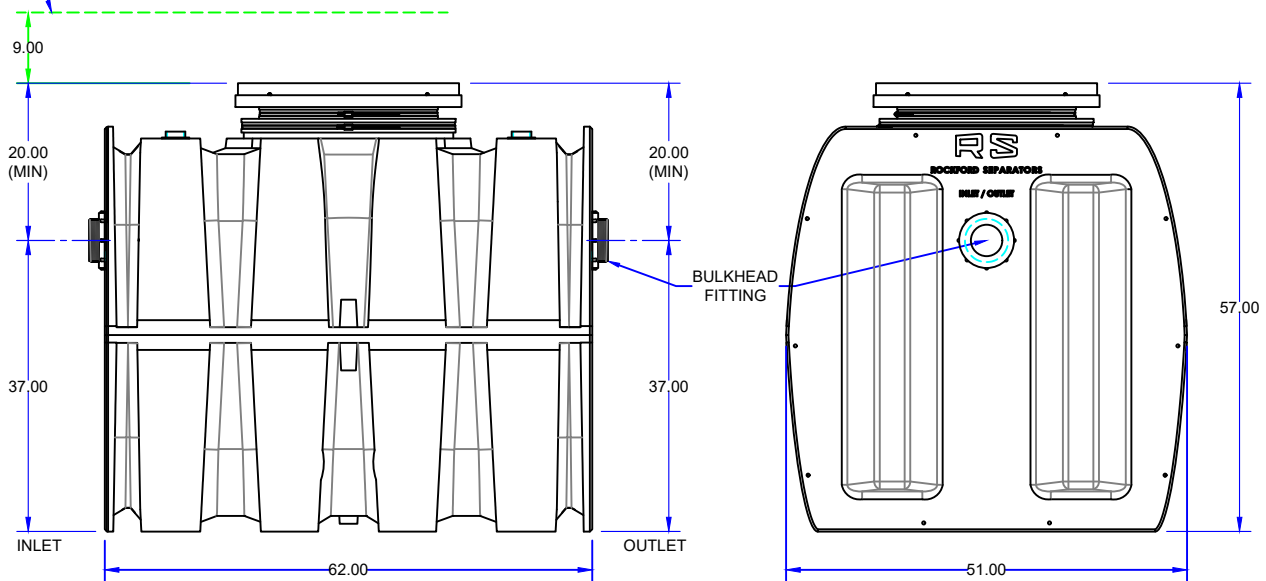

NOTE: For high water table applications add anchor brackets to be anchored to anti-float slab (anti-float slab by others). Upward groundwater pressure will require a water tight concrete vault (concrete vault by others).

## SPECIFICATIONS

Rockford Separators Model RSP-500-O high density polyethylene gravity oil/sand interceptor, rotationally molded 3/8" HDPE wall, with 500 gallon capacity, 500 gpm intermittent flow, 4.00" threaded inlet/outlet, (2) 2.00" vent connections (must use one and cap the other), removable HDPE cover for flush with grade installation suitable for pedestrian traffic load (500#), secured with stainless steel HEX head bolts, heavy duty leak-proof gasket, 4 lifting/anchor points, and Limited Lifetime Warranty. Approximate ship weight of 330 Lbs.

\*\*\*NOTE: manufactured in the United States with domestic component content exceeding the current threshold required by BABAA.



Optional features (Additional cost) listed above

Approved By

Company

Date